

## Influence of Composite Lay-Up on the Stability of Channel-Section Profiles Weakened by Cut-Outs – A Numerical Investigation

Katarzyna Falkowicz<sup>1\*</sup>, Paolo Sebastiano Valvo<sup>2</sup>

<sup>1</sup> Faculty of Mechanical Engineering, Department of Machine Design and Mechatronics, Lublin University of Technology, Nadbystrzycka 36, 20-618 Lublin, Poland

<sup>2</sup> Department of Civil and Industrial Engineering, University of Pisa, Largo Lucio Lazzarino, I-56122 Pisa, Italy

\* Corresponding author's e-mail: k.falkowicz@pollub.pl

### ABSTRACT

This paper presents a numerical study on the stability of composite channel-section profiles weakened by cut-outs. Profiles were made from carbon fibre-reinforced polymer (CFRP) laminates and subjected to compression load. Numerical analysis carried out in the Abaqus software allowed us to determine the value of the buckling load and the corresponding buckling form. Four different laminate lay-ups were chosen to study their effects on the buckling behaviour of the profiles. Obtained results help identify the best laminate lay-up to get the highest critical buckling load for perforated columns. The performed analysis shows that [45/-45/90/0]<sub>s</sub> and [90/-45/45/0]<sub>s</sub> composite lay-ups have the greatest impact on the buckling load. Moreover, the introduced perforation caused a change in the buckling form and a decrease in the critical load value.

**Keywords:** composite, laminate, channel-section profile, buckling, post-buckling, cut-out, FEM, stability.

### INTRODUCTION

Thin-walled composite elements are successfully used for many applications in a variety of fields of engineering, including, i.a., aircraft structures [1, 2], civil engineering constructions [3], and space vehicles [4]. Their success is mainly due to their very good mechanical properties, such as high strength and stiffness combined with low weight. However, those structural elements feature also some important disadvantage. Like all composite structures, they may be prone to damage and degradation phenomena [5–7]. Moreover, as all thin-walled structures, they may undergo a loss of stability when subjected to load conditions inducing compressive stresses [8–9]. But, in general, thin-walled composite profiles can still work after the loss of stability and continue to transfer loads, provided that their postcritical equilibrium paths are stable. Several investigations have been conducted on their post-buckling behaviour [10–11]. Most

studies of the literature, however, concern structures without holes or with holes, but made of traditional materials.

Engineering design often requires introducing perforations into profiles to reduce their weight as well as to enable service and maintenance operations. The presence of holes interrupts the continuous distributions of stress and strain in elements and leads to a reduction in load bearing capacity [12, 13]. Therefore, the effect of geometric parameters and shape of holes on structural behaviour is an important issue in practice. Previous investigations on composite plates [14, 15] showed significant effect of the geometric parameters and shape of holes, as well as the composite lay-up on the stability behaviour. It is worth citing also some investigations performed on perforated columns made of traditional materials, like Z-cross-section [16] or T-cross-section [17]. In [18], Authors tested aluminium alloy members weakened by different kind of holes. Their results show that the size and shape of holes influences

the buckling behaviour. Similar investigations were performed [19] also on profiles made of glass fibre-reinforced polymer (GFRP) materials. The present work starts from results obtained in the mentioned paper to select the configuration of holes. Also, a preliminary research is worth being mentioned on perforated profiles with Z-cross-section, where the influence was studied of the localisation and geometric parameters of cut-outs on buckling and post-buckling behaviour [20].

To sum up, the buckling and post-buckling behaviour of thin-walled structures, as well plate elements, with cut-outs has been extensively researched and described. However, there are very few research related to buckling and post-buckling behaviour of composite perforated columns, which include, i.a., the effects of layers

arrangement. This was the first the motivation to carry out the present analysis, whose main aim was to test the influence of laminate lay-up on the stability of axially compressed, composite, perforated, C-shaped channel-section columns.

### THE STUDY SUBJECT

The study concerns thin-walled perforated columns with channel cross-section, subjected to axial compression. Investigated columns were made of carbon fibre-reinforced polymer (CFRP) laminates, made of carbon fibres and epoxy resins. The mechanical properties of a single lamina are listed in Table 1. The laminates consisted of 8 layers arranged symmetrically with respect to

**Table 1.** Mechanical properties of a CFRP lamina

Elastic properties				
Young's modulus [MPa]		Shear modulus [MPa]	Poisson's ratio	
$E_1 (0^\circ)$	$E_2 (90^\circ)$	$G_{1,2}$	$\nu_{12}$	
143530	5826	3845	0,36	
Strength properties				
Tensile strength [MPa]		Shear strength [MPa]	Compression strength [MPa]	
$F_{TU1} (0^\circ)$	$F_{TU2} (90^\circ)$	$F_{SU} (45^\circ)$	$F_{CU1} (0^\circ)$	$F_{CU2} (90^\circ)$
2221	49	83.5	641	114

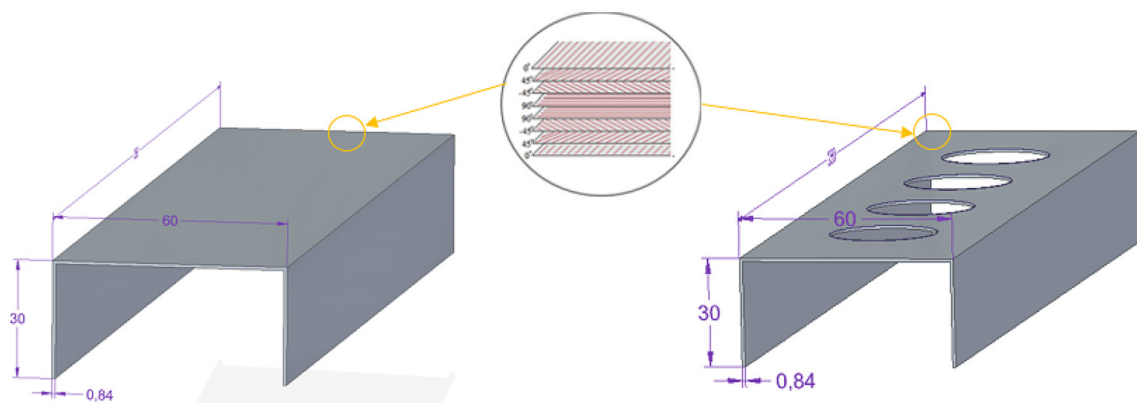

**Fig. 1.** Overall geometric parameters of the profile

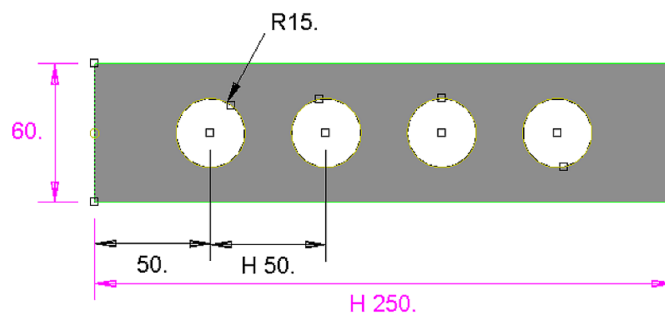

**Fig. 2.** Geometry of holes

the mid plane. Each single layer had a thickness of 0.105 mm and the total thickness of the profile was 0.84 mm. Four different lay-ups were considered for the laminates:

- P1:  $[0/45/-45/90]_s$ ,
- P2:  $[45/-45/90/0]_s$ ,
- P3:  $[90/-45/45/0]_s$ ,
- P4:  $[90/0/90/0]_s$ .

The overall column dimensions are presented in Figure 1. The geometric parameters of holes are shown in Figure 2.

The shape and dimensions of holes was chosen based on the previous work [19, 20], where the influence was tested of three parameters (opening ratio, spacing ratio, and hole shape) on the buckling load. Circular shaped holes gave the highest values of critical load. Therefore, we also consider circular holes here. Moreover, to investigate the influence of cut-outs, we will compare our results with those of unperforated profiles, which have been tested in previous works [21, 22].

## NUMERICAL SIMULATIONS

The numerical analysis was performed in Abaqus program by using the finite element method, which is now very popular and widely used [23–25]. Analysis was carried out in two stages. The first stage was the linear stability analysis,

based on the solution of the following generalised eigenvalue problem:

$$[[K] + \lambda_i [H]] = 0 \quad (1)$$

where:  $K$  – the elastic stiffness matrix;  
 $\lambda_i$  – the  $i$ -th eigenvalue;  
 $H$  – the stress-dependent (also called geometric) stiffness matrix.

The second stage of analysis tackled the non-linear stability problem, based on the incremental-iterative Newton-Raphson method. This analysis allowed us to determine the equilibrium path for the structure. The calculations were performed until failure initiation of first layer according to the Tsai-Wu criterion [26].

The boundary conditions for the tested profiles are presented in Figure 3. The numerical model consisted of two rigid plates, which supported the structure. The lower plate was fully fixed and the upper one had the possibility to move in the direction of compressive force, along to the Z axis. The boundary conditions were defined in a reference point (RP), connected to plates. Between the plates and composite profile contact interaction was introduced with friction coefficient of 0.2.

The discrete model was prepared by using shell finite elements (S8R) with reduced integration. The global mesh for the profiles had a size of 4 mm. This size was decided after conducting a convergence study for three different

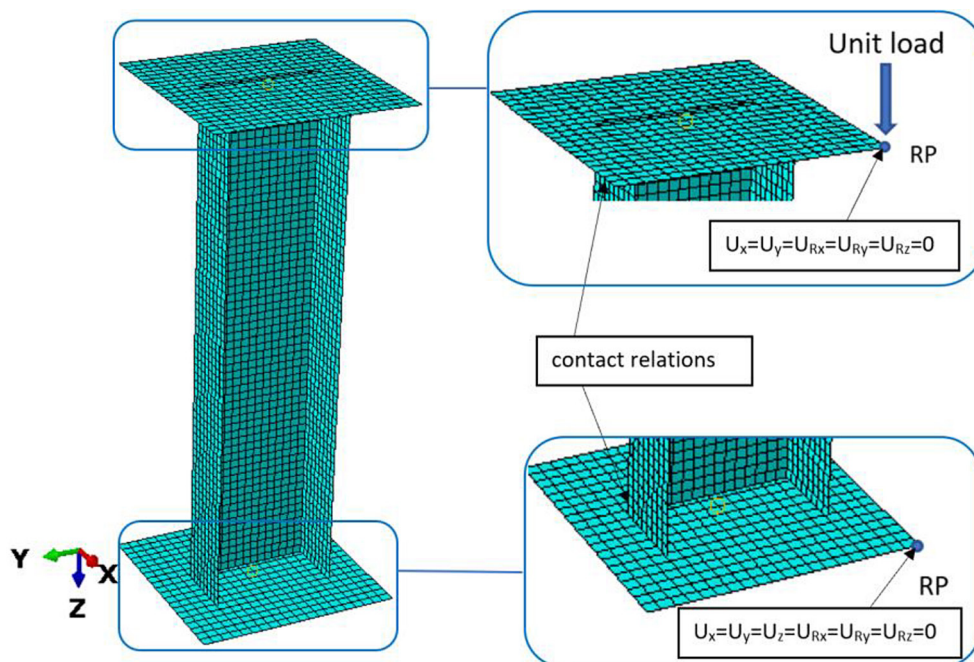

Fig. 3. Boundary conditions of tested column

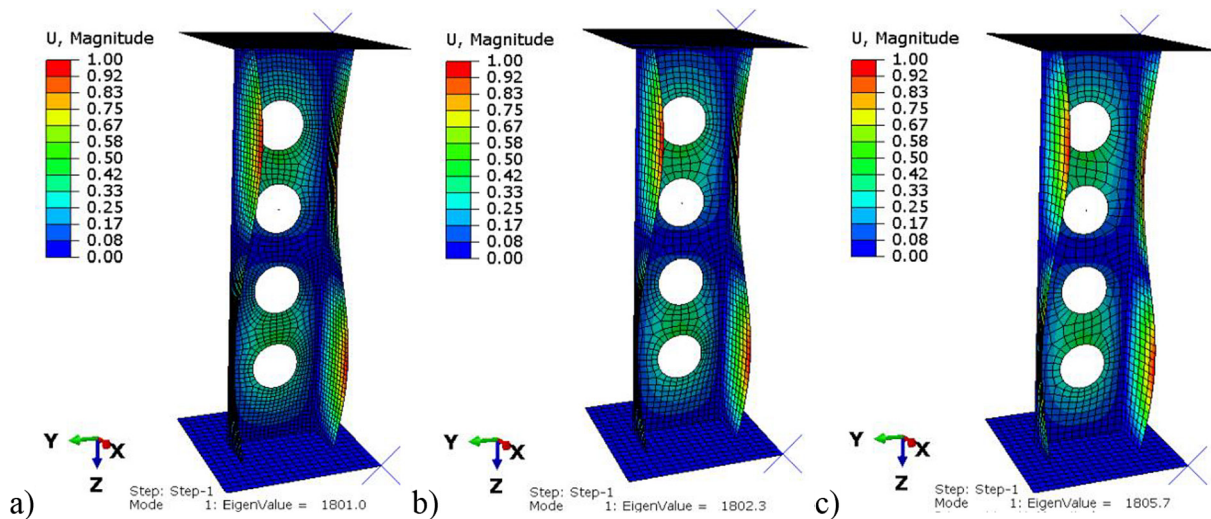

Fig. 4. Mesh size effect on the buckling load value: (a) mesh size = 3 mm, (b) mesh size = 4 mm, and (c) mesh size = 5 mm

mesh sizes: 3 mm, 4 mm, and 5 mm. The test was conducted for perforated profile with P1 lay-up. The effects of mesh size on the buckling behaviour are presented in Figure 4. As can be seen, the mesh size has no significant influence on the critical load value and stability behaviour of profiles. The percentage difference is around 2%.

## RESULTS AND DISCUSSION

In this section, we illustrate the main results of our numerical analysis. Table 2 shows the obtained values of critical loads for perforated and unperforated profiles, for all tested lay-ups. Additionally, Figure 5 presents the results in the form of a column chart. In Figures 6–9, the

Table 2. Values of critical load

Laminate lay-up	Symbol	Pcr [N]		Difference [%]
		Unperforated profile	Perforated profile	
[0/45/-45/90/0]s	P1	2172.4	1802.3	17.04
[45/-45/90/0]s	P2	3259.3	2761.5	15.27
[90/-45/45/0]s	P3	2183.3	1788.5	18.08
[90/0/90/0]s	P4	1590.6	1124.2	29.32

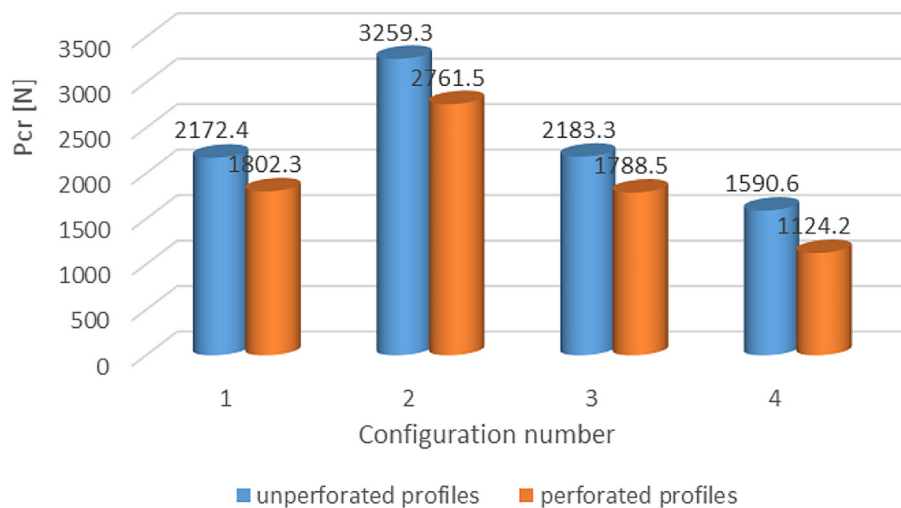

Fig. 5. Effect of opening ratio and space ratio on critical buckling load for different holes shapes

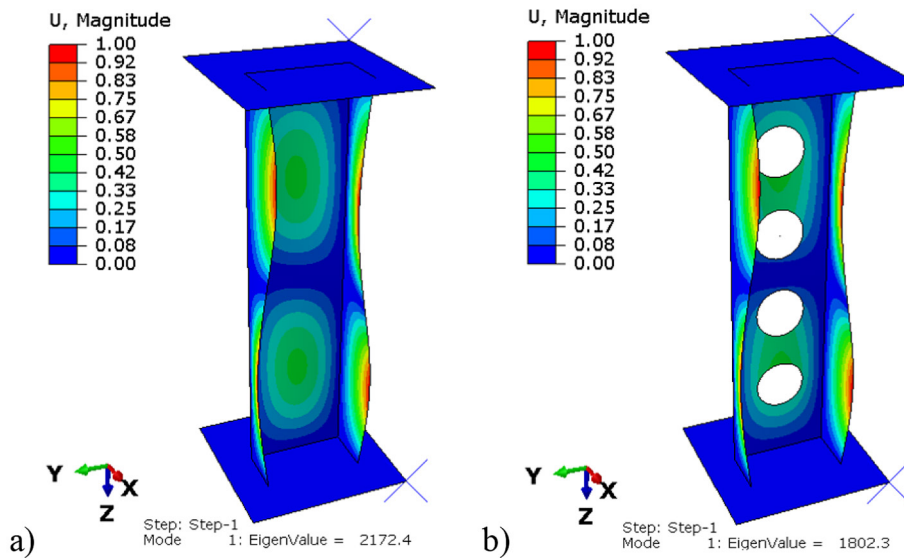

Fig. 6. Buckling simulation results for the P1 lay-up: (a) profile without holes and (b) perforated profile

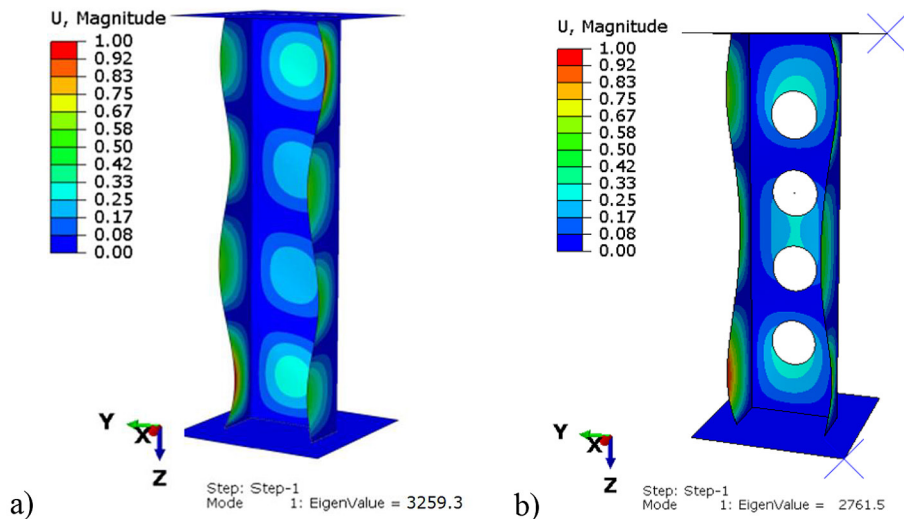

Fig. 7. Buckling simulation results for the P2 lay-up: (a) profile without holes and (b) perforated profile

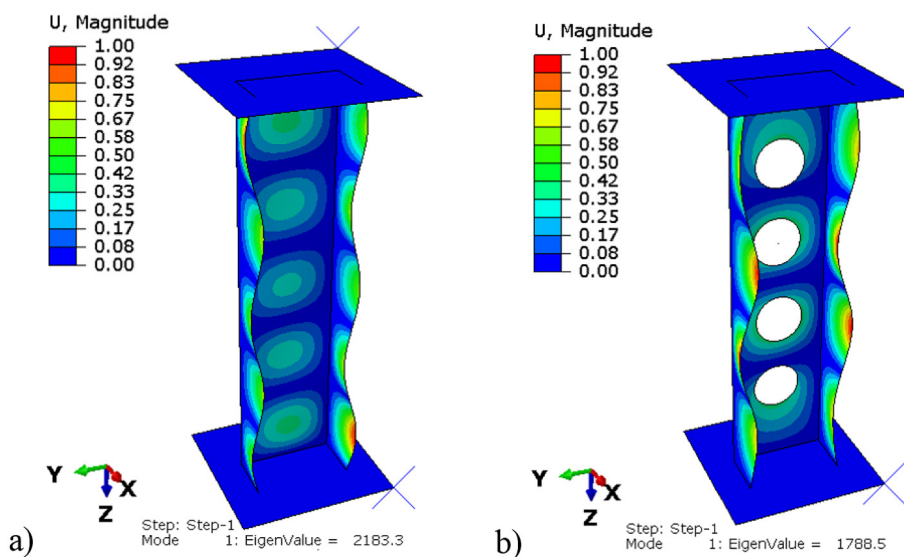

Fig. 8. Buckling simulation results for the P3 lay-up: (a) profile without holes and (b) perforated profile

calculated first buckling form is compared for four different lay-ups [27].

The highest critical load was calculated for the P2 lay-up, while the lowest one was for the P4 lay-up. The obtained results show a decrease in the values of the buckling loads due to the introduction of perforation – which was fully expected. However, we observe that differences are less than 20% for three tested lay-ups. Only for the P4 lay-up the difference was larger than 20%. The highest value of critical load was for the P2 lay-up and the lowest for the P4 lay-up. This is ascribable to the fact that for P2 the most outer layers are at angle of 45 degrees, whereas for P4 the lay-up consists of few layers at an angle of 90 degrees, which reduces the overall structural stiffness. In all cases, the shape of the buckling mode maintained its symmetrical character with respect to the symmetry plane of the C-profile [28].

The above results indicate that the laminate lay-up, as well as the perforation, has significant effect on the buckling behaviour of the tested profiles. For almost all lay-ups, the local buckling of the web and shelves was characterised by different number of half-waves. More in detail, the number of half-waves for the perforated profiles was less by one compared to the unperforated profiles [29]. For example, for the P4 lay-up, the perforation causes a change in the quantity of half-waves from 4 to 3. The maximum deformations of columns, for the P1 and P2 lay-ups were on the shelf closer to the rigid plate and for the P3 and P4 lay-ups in the middle of profile shelf.

According to the main aim of work, the non-linear stability of structure in the post-buckling range was additionally investigated. Figure 10a presents the obtained equilibrium paths for the perforated ( $p$  symbol) profiles with all of the

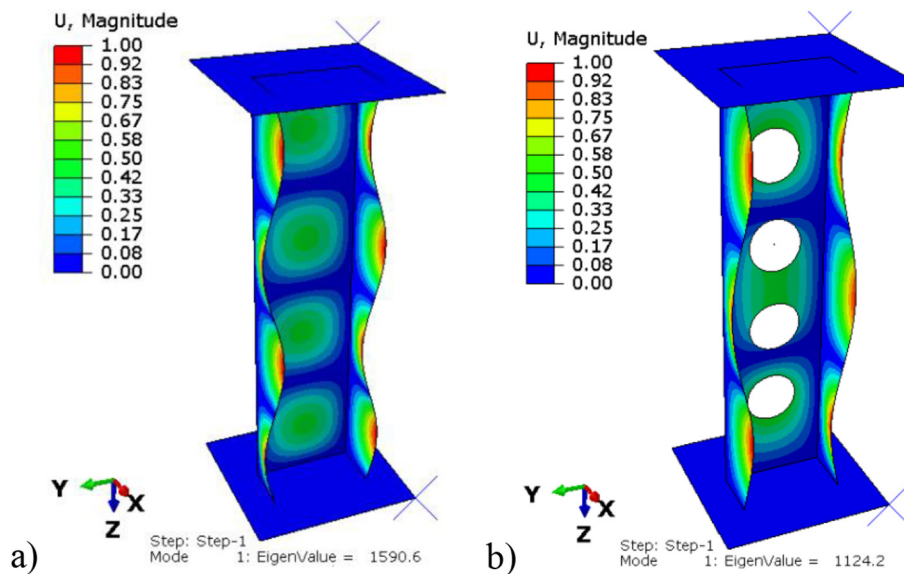

Fig. 9. Buckling simulation results for the P4 lay-up: (a) profile without holes and (b) perforated profile

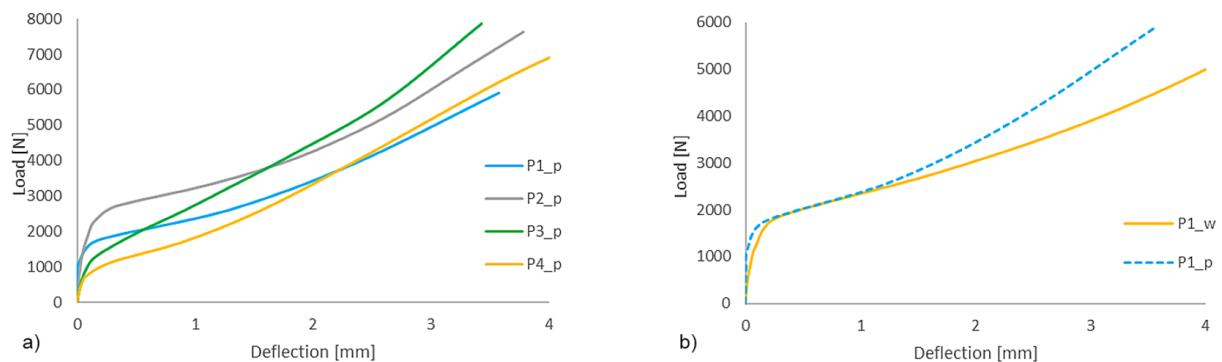

Fig. 10. Post-buckling equilibrium paths for (a) perforated profiles with all lay-ups, (b) for perforated and unperforated profiles with P1 lay-up

lay-ups considered. Whereas, in Figure 10b, the equilibrium paths are compared for the perforated and unperforated ( $w$  symbol) profiles with P1 lay-up. The equilibrium paths plotted show the applied load vs. the maximum transverse displacement of the column wall. The calculations were carried out until failure initiation of first layer.

The obtained results show that for all of the tested profiles, the post-buckling equilibrium paths are stable. Besides, the post-buckling behaviour of perforated and unperforated profiles is similar at the beginning. However, along with the deepening of the deflection, the differences between the equilibrium paths increase. The highest deflection at failure was observed for the P4 lay-up and the lowest one for the P3 lay-up. What is more, the equilibrium path for the P2 laminate lay-up seems to be the one with the highest stiffness.

## CONCLUSIONS

We have investigated the influence of laminate lay-up on the stability of channel-section profiles weakened by cut-outs. Numerical analysis was conducted to compare the buckling and post-buckling behaviour of perforated and unperforated profiles subjected to axial compression. On the basis of the obtained results, some conclusions can be drawn. The arrangement of laminate layers has a significant effect on the stability of perforated profiles. The highest critical load was obtained for the P2 lay-up, while the lowest one for the P4 lay-up. The introduced perforation caused not only a decrease in the critical load value, but also a change in the buckling form. The decrease of the critical load for all tested configurations was respectively: 17.4% for P1, 15.27% for P2, 18.08% for P3 and 29.32% for P4.

The presented results allow us to expand our knowledge about the design of thin-walled composite structures weakened by holes with potential significance for practical applications. However, to confirm the obtained numerical results, a deeper analysis of nonlinear stability conditions and experimental validation are necessary.

## Acknowledgments

The project/research was financed in the framework of the project Lublin University of Technology-Regional Excellence Initiative, funded by the Polish Ministry of Science and Higher

Education (contract no. 030/RID/2018/19). The first Author gratefully acknowledges financial support from the University of Pisa, Italy, through the Visiting Fellows Programme 2022.

## REFERENCES

1. Budarapu P.R., Yb S.S., Javvaji B., Mahapatra D.R. Vibration analysis of multi-walled carbon nanotubes embedded in elastic medium. *Front Struct Civ Eng.* 2014; 8(2): 151–159.
2. Kopecki T., Mazurek P., Lis T., Chodorowska D. Post-buckling deformation states of semi-monocoque cylindrical structures with large cut-outs under operating load conditions. *Numerical analysis and experimental tests.* *EiN.* 2016; 18(1): 16–24.
3. Chróścielewski J., Miśkiewicz M., Pyrzowski Ł., Rucka M., Sobczyk B., Wilde K. Modal properties identification of a novel sandwich footbridge – Comparison of measured dynamic response and FEA. *Composites Part B: Engineering.* 2018; 151: 245–255.
4. Rawal S.P. Metal-matrix composites for space applications. *JOM.* 2001; 53(4): 14–17.
5. Talreja R., Singh C.V. *Damage and failure of composite materials.* Cambridge; New York: Cambridge University Press; 2012. 304 s.
6. Rozylo P., Falkowicz K. Stability and failure analysis of compressed thin-walled composite structures with central cut-out, using three advanced independent damage models. *Composite Structures.* 2021, 273:114298
7. Rozylo P., Wysmulski P. Failure analysis of thin-walled composite profiles subjected to axial compression using progressive failure analysis (PFA) and cohesive zone model (CZM). *Composite Structures.* 2021, 262: 113597
8. Li Z.M., Qiao P. Buckling and postbuckling behavior of shear deformable anisotropic laminated beams with initial geometric imperfections subjected to axial compression. *Engineering Structures.* 2015; 85: 277–292.
9. Falkowicz K., Debski H., Teter A. Design solutions for improving the lowest buckling loads of a thin laminate plate with notch. *22nd International Conference on Computer Methods in Mechanics, CMM 2017. AIP Conference Proceedings.* 2018, 1922, 080004.
10. Paszkiewicz M., Kubiak T. Selected problems concerning determination of the buckling load of channel section beams and columns. *Thin-Walled Structures.* 2015; 93: 112–121.
11. Falkowicz K., Ferdynus M., Rozylo P. Experimental and numerical analysis of stability and failure

- of compressed composite plates. *Composite Structures*. 2021; 263: 113657.
12. Banat D., Mania R.J. Failure assessment of thin-walled FML profiles during buckling and postbuckling response. *Composites Part B: Engineering*. 2017; 112: 278–289.
  13. Debski H., Rozylo P., Wysmulski P., Falkowicz K., Ferdynus M. Experimental study on the effect of eccentric compressive load on the stability and load-carrying capacity of thin-walled composite profiles. *Composites Part B: Engineering*. 2021; 226: 109346.
  14. Rozylo P., Falkowicz K., Wysmulski P., Debski H., Pasnik J., Kral J. Experimental-numerical failure analysis of thin-walled composite columns using advanced damage models. *Materials*. 2021; 14(6): 1506.
  15. Rajan V.P., Zok F.W. Stress distributions in bluntly-notched ceramic composite laminates. *Composites Part A: Applied Science and Manufacturing*. 2014; 60: 15–23.
  16. Toubal L., Karama M., Lorrain B. Stress concentration in a circular hole in composite plate. *Composite Structures*. 2005; 68(1): 31–36.
  17. Falkowicz K., Debski H. Stability analysis of thin-walled composite plate in unsymmetrical configuration subjected to axial load. *Thin-Walled Structures*. 2021; 158: 107203.
  18. Falkowicz K., Debski H. The work of a compressed, composite plate in asymmetrical arrangement of layers. W Depok, Indonesia 2019, 020005. <http://aip.scitation.org/doi/abs/10.1063/1.5092008>
  19. Falkowicz K. Numerical analysis of behaviour of compressed thin-walled Z-profiles weakened by holes. Kulisz M., Szala M., Badurowicz M., Cel W., Chmielewska M., Czyż Z., i in., redactors. *MATEC Web Conf*. 2019; 252: 07010.
  20. Flexural Buckling Analysis of Thin Walled T Cross section beams with variable geometry. *International Journal of Engineering Research*. 2014; 3(3): 9.
  21. Khazaal D.S., AL-Khafaji H.M., Abdulsahib I.A. Buckling behavior of aluminum alloy thin-walled beam with holes under compression loading. *JCO-ENG*. 2020; 26(9): 137–154.
  22. Bin Kamarudin M.N., Mohamed Ali J.S., Aabid A., Ibrahim Y.E. Buckling analysis of a thin-walled structure using finite element method and design of experiments. *Aerospace*. 2022; 9(10): 541.
  23. Falkowicz K. Numerical Investigations of Perforated CFRP Z-Cross-Section Profiles, under Axial Compression. *Materials*. 2022; 15(19): 6874.
  24. Wysmulski P., Debski H., Falkowicz K., Rozylo P. The influence of load eccentricity on the behavior of thin-walled compressed composite structures. *Composite Structures*. 2019; 213: 98–107.
  25. Wysmulski P., Debski H. Stability analysis of composite columns under eccentric load. *Appl Compos Mater*. 2019; 26(2): 683–692.
  26. Jonak J., Karpiński R., Siegmund M., Wójcik A., Jonak K. Analysis of the rock failure cone size relative to the group effect from a triangular anchorage system. *Materials*. 2020; 13(20): 4657.
  27. Jonak J., Karpiński R., Wójcik A. Influence of the undercut anchor head angle on the propagation of the failure zone of the rock medium. *Materials*. 2021; 14(9): 2371.
  28. Jonak J., Karpiński R., Siegmund M., Machrowska A., Prostański D. Experimental verification of standard recommendations for estimating the load-carrying capacity of undercut anchors in rock material. *Adv Sci Technol Res J*. 2021; 15(1): 230–244.
  29. Tsai S.W., Wu E.M. A General Theory of Strength for Anisotropic Materials. 23.