

## GRINDING OF SHAPED TOOLS ON CNC TOOL GRINDER

Ján Král<sup>1</sup>, Ján Král Jr.<sup>2</sup>

<sup>1</sup> Faculty of Mechanical Engineering, Department of Technologies and Materials, Technical University of Košice, Slovakia. e-mail: jan.kral@tuke.sk

<sup>2</sup> Faculty of Mechanical Engineering, Centrum of Informatics, Technical University of Košice, Slovakia, e-mail: kral.jan@tuke.sk

Received: 2012.10.22  
Accepted: 2012.12.03  
Published: 2013.03.15

### ABSTRACT

Worm gears are special gears consisting of a worm wheel and a worm. Worm gears can be produced in different ways, depending on the size of the transmission, the number of courses, the pitch angle of worm profile, the number of units produced, the purpose of application, etc. As cylindrical worm gears we consider the cylindrical worms with globoid gears, globoid worm with globoid worm gear and globoid worm with cylindrical worm gearing. This paper deals with the evolvent worm whose curve of the tooth side in the front plane is evolvent. The production of worm with an optimal profile for optimal meshing conditions is an increasingly frequent focus of worm gear manufacturers. The problem of designing the tool cutting edge can be divided into several steps. This article deals with the problems of optimum design of a tool shape for the production of worms; and the problems of calculating the coordinates of the transition cutting edge shape, and thus the path of grinding wheel for sharpening the tool cutting edge shape are solved. By grinding tool of grinding machine we can complete the worm shape and also sharpen the cutting edges of tools for production of worm surface. The problems of calculation of the coordinates are solved with regard to the functioning of the KON 250 CNC grinding machine logic.

**Key words:** shape, profile, tool grinder, worm gear, operation.

### INTRODUCTION

The problem of production of optimal worm profile consists of technically acceptable calculations (applicable in practice) to produce optimum shape of tool cutting edges or profile of the grinding wheel. To carry out simulations for optimal meshing gear pairs, the analysis of computational methods for designing the shape of the tool cutting edge based on the manufacturing possibilities must be realized [1, 5].

The analysis and computational relations are solved using computer technique because it is the fastest and cheapest way to achieve the best results.

The tool grinder KON-250 CNC can manufacture shapes of tool cutting edges, exact shapes of templates to shape the abrasive wheel and also different geometrical shapes and profiles [2, 4].

The methodology of control programming system for CNC tool grinder (tool cutting edge) is described to manufacture the shapes of tool cutting edges and also the templates for dressing abrasive wheels. This article describes the operating principles of the KON-250 CNC tool grinder to familiarize with basic parameters and principles and subsequently to re-consider them in determining the algorithm.

### CHARACTERISTICS OF THE GRINDER

Grinding machine KON-250 CNC is designed to grind the shaped surfaces [2]. Supplementary equipment of this grinder is the control unit with memory. Grinding various shapes can be carried out by [3]:

- manual feed control according to the template in the scale,
- machine feed control according to specified NC program.

Saving the NC program can be implemented by eight-track punch tape or alpha-numeric keypad, and modifications of program saved already in memory are possible.

The machine enables also the drawing of profile to be ground by using special equipment in order to check the accuracy of NC program by visual observation and also application of NC program generated by the control unit on the external punched tape.

By this grinder the geometric shapes such as e.g. lines, circles and circular arcs, general curves replaced by a number of points or circles and their centers can be ground [6]. Grinding precision is  $\pm 0,005$  mm.

### GRINDING OF CUTTING EDGE SHAPES AND TOOL PROFILES FOR WORM GEAR PRODUCTION

In grinding the line shaped tools, the end point of line to be ground must be always specified. If design consists of polygons (created by combining multiple lines) they need to be linked up, i.e. the end point of the  $i$ -line is the starting point of  $i+1$ -line. In grinding circles, the end point of a circular arc and also the center of the circle must be specified.

For grinding general curves it is necessary to specify a set of points of the curve. The coordinates of these points should be graded by 0.01 to 0.05 mm, to achieve a sufficient accuracy of curve shape and also smooth transition between single points.

Figure 1 shows an example of cutting edge shape creation and representation of abrasive

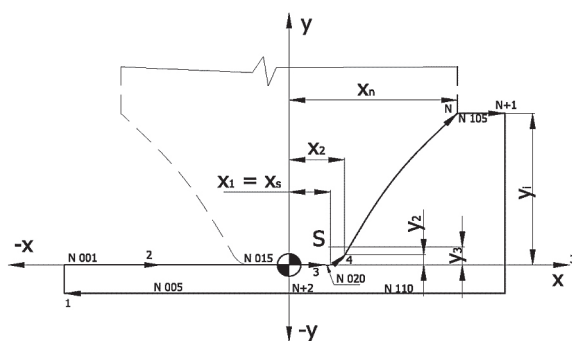

Fig. 1. Programming of line and geometric shapes

wheel, point and its path from point “0” through the points (1, 2, 3...) up to point “N+2”. This example presents the programming of a linear shape (points 2 and 3), circular arc (points 3 and 4) and also general curve (points 4 to N).

To grind the shape shown in Figure 1 we can use following program:

```

N 005 G 90 G 00 X-50000 Y-3000
N 010 G 90 G 00 X-15000 Y 0 M 00
N 015 G 90 G 01 X 10000 Y 0 F 60
N 020 G 90 G 02 X 20000 Y 15000
      I 10000 J 18000 F 60
N 025 G 90 G 01 X ... Y ... F 60
.
.
N 105 G 90 G 01 X ... Y ... F 60
N 110 G 90 G 00 X 0 Y-3000 M 30
    
```

(Note: coordinates of points in program are only general)

where:

- N 005, N 010 ... N 110 – number of sentences,
- G 90 – coordinates in absolute system,
- G 00 – fast infeed to program point,
- G 01 – control method using information inside the sentence to create a straight line,
- G 02 – circular interpolation control applying information within a sentence to create circular arc; relative tool movement to the workpiece is clockwise,
- G 03 – circular interpolation control, tool path relative to the workpiece is counter-clockwise,
- X, Y – coordinates of points 1, 2,... N+2 [mm],
- M 00 – unconditional stop after finishing instructions in the sentence,
- M 30 – end of punch tape, end of program,
- F 60 – grinding process,
- I – x coordinate of curvature centre,
- J – y coordinate of curvature centre.

Each program must start with two rectangular coordinates and it is necessary to define the abrasive wheel radius of truing “R”. Based on NC program for defined radius of abrasive wheel, control unit ensures determination of an appropriate path considering the abrasive wheel radius.

Profile made on grinding machine can be shifted to achieve the specified tool width (Fig. 2). Abrasive wheel moves along the equivalent path shifted (increased or decreased) to the value specified by decimal switch. Decimal switch is independent for x and y coordinates.

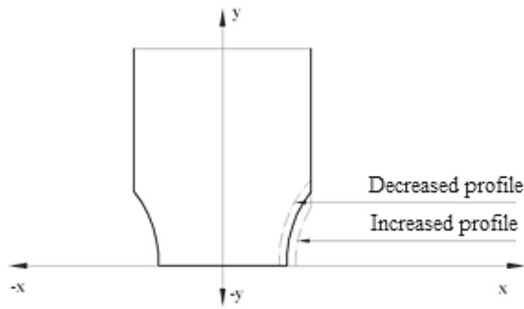

Fig. 2. Profiling of tooth side

**DETERMINATION OF COORDINATES OF CENTRE OF TOOL CUTTING EDGE CURVATURE**

We obtain computer aided cutting edge shape (its coordinates) in normal or axial sections based on analytical description of worm surface. This shape is bounded by foot and head diameters. When grinding the shape of the tool cutting edge by the KON-250 CNC grinder there is a problem with the determination of cutting edge curvature whose size can be calculated as follows:

$$\rho_{ko} = 0,20m \text{ to } 0,30m$$

where:  $m$  – gear module.

It is recommended to choose the radial gap size on the worm wheel tooth space according to the relationship:

$$c_a = 0,20m$$

In justified cases the change is allowed:

$$c_a = 0,15m \text{ to } 0,30m$$

To determine easily the coordinates of centre of curvature “S” (Fig. 3) it is preferred to choose the radius of curvature  $\rho_{ko}$  and size of radial (head) gap  $c_a$  as follows:

$$c_a = \rho_{ko}, \text{ or } c_a \cong \rho_{ko}$$

Then the coordinates of point “S” are calculated using equations:

$$x_s = x_B - \rho_{ko}$$

$$y_s = y_B$$

where:  $x_B, y_B$  – coordinates of end (head) point of the curve of the side cutting edge (Fig. 3) in the case that:

$$\rho_{ko} > c_a$$

Then we determine the coordinates of the center of curvature “S” by calculation. For suf-

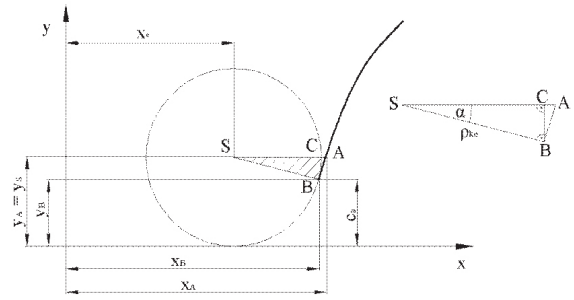

Fig. 3. Tooth surface and root profile surface in manufacturing of worm wheels

ficiently small section AB we can replace profile curve by straight line with satisfactory accuracy, and from triangle SBC (Fig. 3) it follows:

$$\cos \alpha = \frac{\overline{SC}}{\rho_{ko}},$$

if we denote  $\rho_{ko} = r$ , then we obtain:

$$\overline{SC} = r \cdot \cos \alpha$$

$$\overline{BC} = r \cdot \sin \alpha \tag{1}$$

and as shown in Figure 3:

$$\tan \alpha = \frac{x_A - x_B}{y_A - y_B}$$

then:

$$\alpha = \arctan \frac{x_A - x_B}{y_A - y_B} \tag{2}$$

For coordinates of the centre of curvature it is valid:

$$x_s = x_B - \overline{SC}$$

$$y_s = y_B + \overline{BC} \tag{3}$$

By substitution we obtain:

$$x_s = x_B - r \cdot \cos \left( \frac{\arctan(x_A - x_B)}{y_A - y_B} \right)$$

$$y_s = y_B + r \cdot \sin \left( \frac{\arctan(x_A - x_B)}{y_A - y_B} \right) \tag{4}$$

where: coordinate  $x_A$  corresponding to coordinate  $y_B$  is obtained as output from computer.

**SUMMARY**

Programming the shape of the cutting edge is carried out in G-code and the shape of the profile can be calculated by manual or automated programming. Such profile is characterized as the intersection of the main front and back surfaces. For completed calculation of the shape of the cutting edge, the curve of profile creating radius

on the root of the worm tooth is also important. The given method for calculation of coordinates of center of curvature is approximate but sufficient. Assuming that the curvature at the root of the worm wheel tooth is not in contact with the worm during intermeshing, the above mentioned simplification can be accepted.

## REFERENCE

1. Král J. 1994. Výpočet, konštrukcia a výroba rezných nástrojov pre závitovkové prevody pomocou výpočtovej techniky. Habilitačná práca, Košice: TU, p. 102.
2. Flisiak J., Józwiak J. 2006. Zastosowanie oprogramowania CAD/CAM w procesie kształcenia studentów. Informatyka w Kształceniu t. I. pod red. Lennik K., Borowski G., Lub. Tow. Nauk., Lublin.
3. Řehoř J., Hofmann P., Hort P. 2001. Tvorba třísky a další průvodní jevy při HS frézování vysoko- legované nástrojové oceli v zušlechteném stavu. In: ICPM 2001. Mezinárodní kongres Přesné obrábění: sborník přednášek. Ústí nad Labem: UJEP, pp. 199-208.
4. Ižol P. 2008. Porovnanie prístupov k tvorbe programov pre NC stroje. Acta Mechanica Slovaca 12(3-A): 175-180.
5. Vasilko K., Novák, Marcišin J., Havrila M. 2003. Výrobné inžinierstvo. TU Košice.
6. Stančeková D., Štekláč D., Czán A. 2008. Nové informácie o orovnávaní brúsnych kotúčov. Progressívne metódy vo výrobných technológiách, medzinárodné sympóziu v rámci projektu CEEPUS CII-CZ-0201-02-0809: Súľov. Vedeckotechnická spoločnosť pri ŽU v Žiline, pp. 86-91.