

Increasing the Carrying Capacity of the Solid-Body Rail Freight Car

Denys Baranovskyi^{1*}, Sergey Myamlin², Ivan Kebal³

¹ Faculty of Mechanics and Technology, Rzeszow University of Technology, ul. Kwiatkowskiego 4, 37-450, Stalowa Wola, Poland

² Department of Development and Technical Policy, JSC “Ukrainian Railway”, Jerzy Giedroyc Str. 5, 03150, Kyiv, Ukraine

³ Department of Wagons, The Dnipro National University of Railway Transport named after academician V. Lazaryan, Lazaryana Str. 2, 49010, Dnipro, Ukraine

* Corresponding author’s e-mail: d.baranovsky@prz.edu.pl

ABSTRACT

In paper has been carried out to develop a load-bearing floor to increase the carrying capacity of the solid-body rail freight car. An analysis of the structures made it possible to formulate the hypothesis that the load-bearing floor of the solid-body rail freight car should have a different cross-sectional shape. As a result, the load-bearing floor of the solid-body rail freight car was proposed, making it possible to reduce the consumption of materials by 1 to 2%. The maximum equivalent stresses (according to Mises) of the proposed load-bearing floor of the solid-body rail freight car in static analysis are 210.7 MPa, which is less than the yield limit of simple carbon steel. The proposed technical solution allows one to increase the carrying capacity of the solid-body rail freight car by 1.4–1.7 tons. The proposed technical solutions for the future operating conditions of rail freight cars make it possible to reduce the number of units in a train by 1–2 units while maintaining the gross weight of the train.

Keywords: load-bearing floor, rail freight car, carrying capacity, static analysis, design.

INTRODUCTION

Worldwide, the railway is a strategic means of transportation for all countries. As a result, many shipments are produced in the railway industry, producing all types of transport products. The continued development of railways requires new design solutions in the development of modern rolling stock that will first and foremost provide a high level of reliability [1] and therefore ensure the improvement of traffic safety [2–4] that would lead to economic growth of the railway industry.

The design development of the new rolling stock will allow improving the technical and economic parameters, reducing the transport costs in the price of transported products, accelerating the modernization of the material and technical basis of rail transport [5], increasing the weight of the train to reduce the unit cost of energy for traction,

speed up the promotion of freight traffic, improve safety, reliability, and availability. All these principles are laid at the outset of the creation of the rail freight car named design. Improving the design affects both the undercarriages of the rail freight cars and the bodies.

The solution of such problems requires the improvement of the basic structures of the solid-body rail freight car (SBRFC) according to several of the most important technical, economic, and integral criteria that correspond to the level of technical and economic indicators of the railways. One of the most important technical and economic indicators of SBRFC is the consumption of materials, whose reduction is one of the priority areas for improving their design. Reducing the material consumption of SBRFC allows one to increase the carrying capacity.

Well-known ways to reduce the material consumption of SBRFC are as follows:

- Reduction of effort;
- Optimization of constructive forms;
- Rational choice of materials;
- Improvement of manufacturing and repair technology.

Currently, to reduce the material consumption of SBRFC structures, the choice of rational sections and materials is used. Reducing the material consumption of SBRFC based on scientific and technical solutions will lead to an increase in carrying capacity.

The aim of the article is to increase the carrying capacity of SBRFC. New SBRFC designs should be created regardless of their purpose, taking into account current and future operational requirements, and ensuring safety, durability and reliability [6, 7]. In addition, they should provide maximum comfort and the lowest cost in the manufacture, maintenance, and repair of the SBRFC in operation and should also provide the ability to upgrade. Particular attention should be paid to the design to ensure the safety of staff. The design should not defect SBRFC and the safety of the transported cargo during transport and shunting.

STRUCTURAL FEATURES OF THE SBRFC

In Europe, rail freight cars are used to a greater extent for the transport of inert cargo, primarily coal. For example, Polish rail freight cars, series E, are called wagons for the transport of coal [6, 8]. The German company SCHENKER produces SBRFC with a retractable roof model 889 [6, 9].

In China, the situation is similar; bulk cargo is transported, for example, C70, C80, C80B cars [9].

A feature of the car building industry in the United States and Canada is the increase in the carrying capacity of SBRFC not as a result of an increase in the number of axles, but as a result of the application of high axle loads on the rails, which for most of these cars amounts to 32.5 tons/axle. This allows the construction of a four-axle rail freight car with a carrying capacity of up to 100 tons [6, 7, 9].

To reduce the metal consumption of the rail freight car, aluminum and magnesium alloys are used [10–12], as well as honeycomb and sandwich panels [13, 14]. However, its use leads to an increase in the cost of a freight car. Next, consider the SBRFC 12–757-ЭИ-2 (Ukraine). The general view of the SBRFC 12–757-ЭИ-2 is shown in Figure 1 [9].

SBRFC frames have large floor cross-sectional areas and widened cross-beams to increase the floor cross-section (Fig. 2).

The SBRFC construction analysis [7] showed that the load-bearing floor is made of rolled sheet; In certain cases, an additional sheet is stamped to form ribbed protrusions, to increase strength, and to use materials that have lower specific gravity and greater strength.

In Ukraine, the material of the SBRFC is used steel 09G2C with yield limit 345 MPa. The thickness of the load-bearing floor of the SBRFC can be from 6 mm.

Load-bearing floor reduces the stress in the bearing elements of the frame, so the SBRFC to the carrier floor there is an additional provision for reduction of metal framing members. At the same time, the load-bearing floor is subjected to the simultaneous action of vertical and horizontal loads. In this case, the action of the vertical



Fig. 1. General view of the rail freight car 12–757 ЭИ-2 (Ukraine) [9]

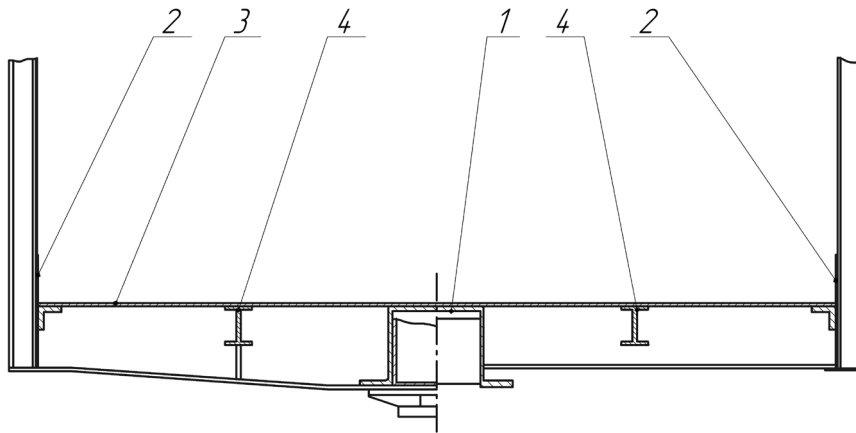

Fig. 2. Sketch of the cross-section of SBRFC (cross-section of the beam and pivot in the middle of the frame): 1 – spinal beam; 2 – lower trim of the side wall; 3 – load-bearing floor; 4 – cross-beam

load bearing elements obtained the deflection, the magnitude of which determines the occurrence of bending moments resulting from horizontal loads and other stresses. Such additional bending moments can be caused by the primary curved carrier.

Stress analysis is complicated by the fact that under the action of bending moments from the horizontal deflection, increased compressive loads, i.e. the geometrically nonlinear problem is.

In various studies, the effects of the initial curvature of the stress reinforcement elements are analyzed in the body of the state and ways to optimize the load-bearing elements, with initial geometric imperfections. When the calculations are given, the initial camber load-bearing floor tells the body plate model SBRFC, i.e., introduced the initial deflection sheets in each bay floor (Fig. 2) by creating the appropriate frame geometric model and finite element model based on it. This sets the value of the initial deflection

f_0 . Each span curvature seems to be a half-wave sine wave between the longitudinal and transverse beams of the frame.

THEORETICAL BACKGROUND FOR THE CREATION OF A NEW SBRFC DESIGN

According to the authors, in the SBRFC there is a promising decrease in metal bodywork. This reduction can be achieved using basic engineering principles and surface-resistance materials.

An analysis of the structures of the SBRFC, as well as an analysis of computational models, made it possible to formulate the SBRFC hypothesis that the load-bearing floor should have a different cross section. Therefore, it is proposed to change the shape of the load-bearing floor in the cross section, as shown in Figure 3.

In the proposed form of load-bearing floor in the design of the SBRFC, the sheet itself will

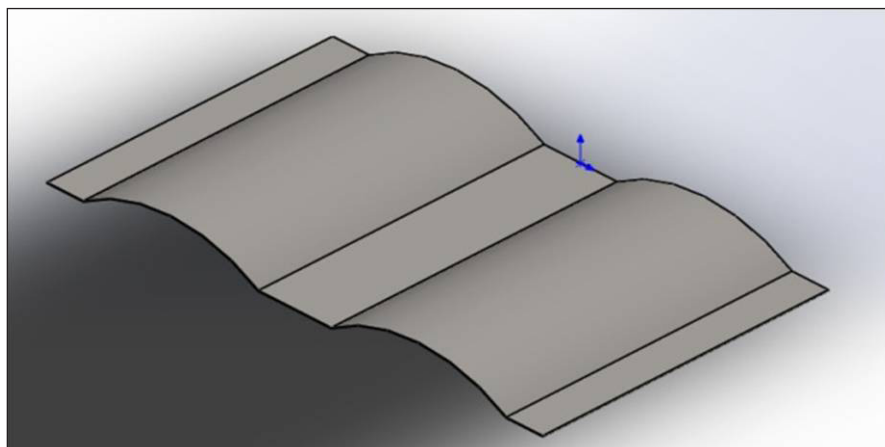

Fig. 3. Profile of the SBRFC load-bearing floor

initially be loaded. The profile will hold even greater loads, since there will be no deflection of the load-bearing floor. This will increase the carrying capacity of the SBRFC. Depending on the thickness of the load-bearing floor, it is possible to reduce the material consumption of the body by 1–2%. At the same time, the thickness on the metal of the load-bearing floor made of simple carbon steel can be 4 mm or more. However, it should be noted that there are negative aspects when using a geometrically modified load-bearing floor. This is a loss of volume, which can range to 1 m³.

Furthermore, when using a geometrically modified load-bearing floor in the SBRFC design, it is possible to remove the support beam 4 (Fig. 2), which will further reduce material consumption by 1.0–1.5%.

A sketch of the SBRFC design with a geometrically modified load-bearing floor is shown in Figure 4.

In such a form, the load-bearing floor is initially loaded sheet itself, that is, the deflections flooring will not, and the profile can take heavy loads. In such a case, increases payload SBRFC can be made, and considering the different thicknesses of load-bearing floor can reduce metal body.

RESEARCH RESULTS

To confirm the hypothesis, theoretical studies have been carried out using the finite element method. The load-bearing floor of SBRFC

is calculated according to [15]. A uniformly distributed load of 80 kN was applied to the load-bearing floor of SBRFC.

We researched a typical SBRFC carrying capacity of 71 tons and a geometrically modified load-bearing floor of 4 mm thick, which is made of plain carbon steel.

For the CAD model of the load-bearing floor, stress, strain, and displacement calculations were performed. The simulation results are shown in Figs. 4–6.

The stress analysis (Fig. 5) of the load-bearing floor under loading showed that the maximum equivalent stresses are 210.7 MPa at yield limit 220 MPa.

Analysis of displacements of the load-bearing floor under loading (Fig. 6) showed that the maximum displacement amount to 1.142 mm.

The analysis of the strains (Fig. 7) of the load-bearing floor under loading showed that the maximum strain is 7.65×10^{-4} .

In addition, studies of CAD models were carried out in static analysis for different thicknesses of the load-bearing floor of the SBRFC under loading. The results of equivalent stresses (according to Mises), displacements, and strains of the CAD models of the load-bearing floor of the SBRFC under loading are shown in Fig. 8.

The CAD model of the proposed load-bearing floor of the SBRFC, 4 mm thick, showed that the maximum equivalent stresses in the static analysis are 210.7 MPa. This value of stresses makes it possible to assert the possibility of using the load-bearing floor to increase the carrying capacity of

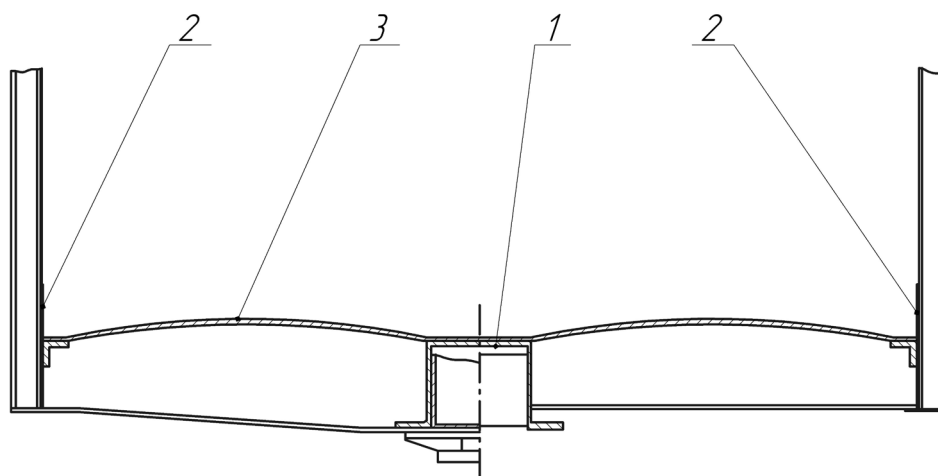

Fig. 4. Sketch of the cross-section of the SBRFC design with a geometrically modified load-bearing floor: 1 – spinal beam; 2 – lower trim of the side wall; 3 – load-bearing floor

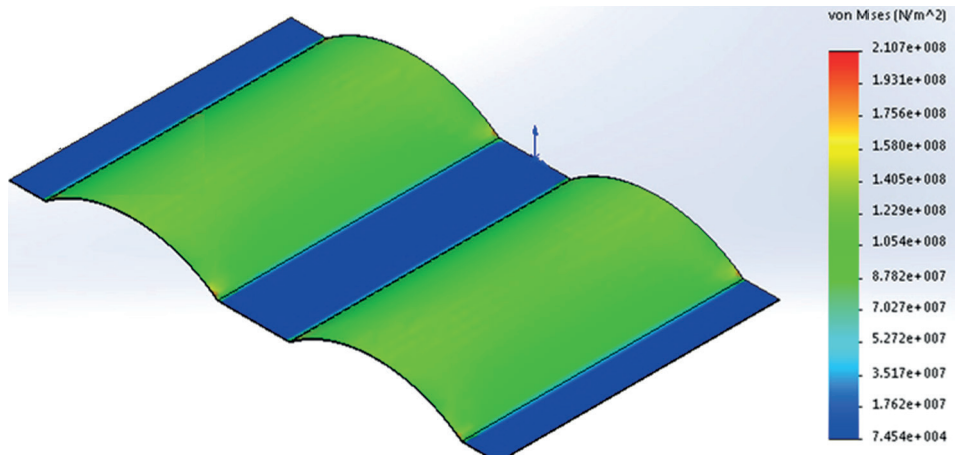

Fig. 5. Equivalent stress of the load-bearing floor under loading

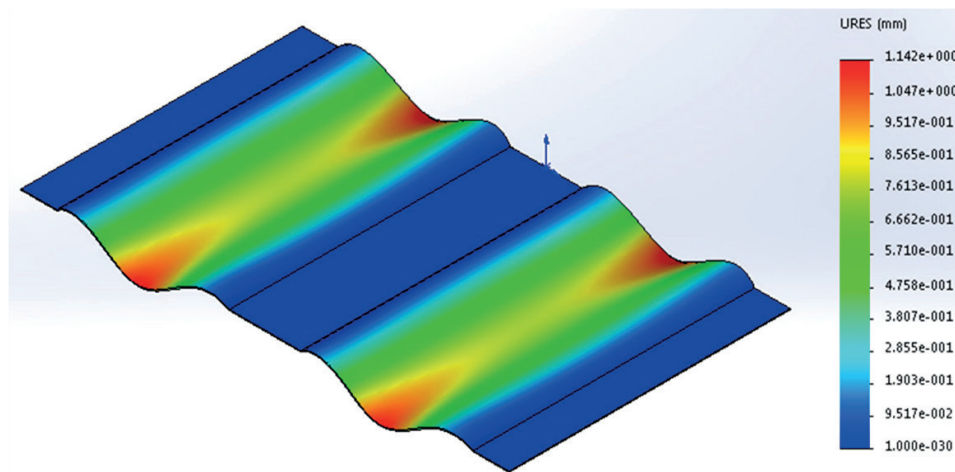

Fig. 6. Displacement of the load-bearing floor under loading

the SBRFC. At the same time, the maximum displacements and strains do not exceed the calculated norms.

Studies carried out on the CAD model with different sheet thicknesses showed obvious things. The graphic dependence (Fig. 8a) indicates the nonlinear component of the maximum equivalent stresses of the proposed load-bearing floor of the SBRFC, the values of which are typical for the corresponding sheet thicknesses. The smallest value of stresses (180.2 MPa) is observed when the thickness of the load-bearing floor is 6 mm. However, the smaller thicknesses of the load-bearing floor of the SBRFC provide a margin of safety in terms of the values of the maximum equivalent stresses.

Maximum displacements are characterized by a linear dependence on the thickness of the

load-bearing floor of the SBRFC (Fig. 8b). It should also be noted that the maximum displacements with a sheet thickness of 4 to 6 mm correspond to the usual deflection, which recently has begun to be taken into account when calculating the strength of various elements of the rail freight car body. The proposed load-bearing floor of the SBRFC will ensure the high stability of the load-bearing elements of the body, both under static loading of various types of bulk cargo and under dynamic loading during transportation.

The nature of the maximum equivalent strains has a nonlinear character along the thickness of the load-bearing floor of the SBRFC (Fig. 8c). With an increase in the thickness of the sheet, the value of the maximum equivalent strains decreases by 25%.

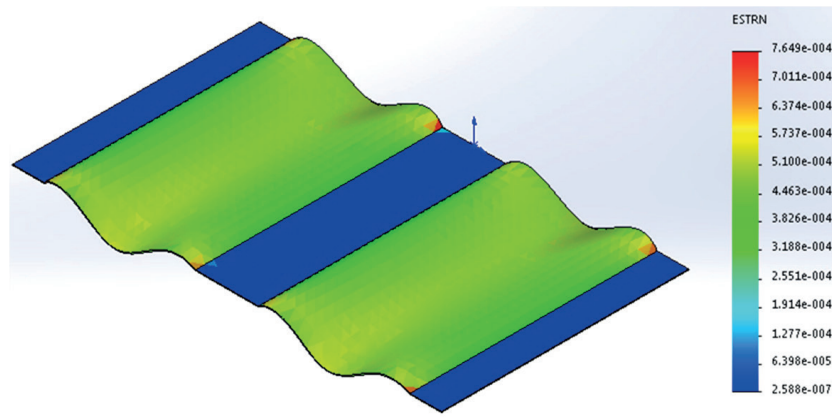

Fig. 7. Strain of the load-bearing floor under loading

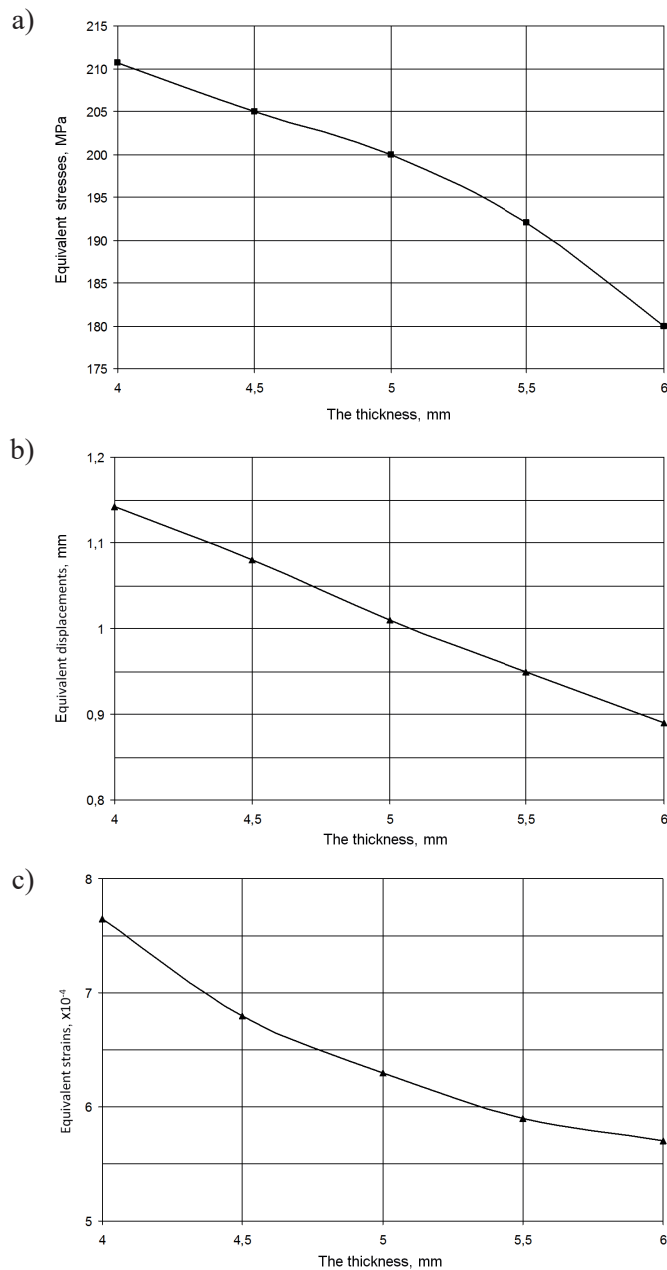

Fig. 8. Maximum equivalent stresses (according to Mises) (a), maximum equivalent displacements (b), maximum equivalent strains (c) in the static analysis of the proposed load-bearing floor of the SBRFC depending on the thickness of the sheet

CONCLUSIONS

Based on the above, we can conclude the suitability of a geometrically altered load-bearing floor of the SBRFC, which reduces the metal consumption of the body structure and thereby increases the load capacity of the considered rail freight car.

The article proposes the load-bearing floor of the SBRFC. This made it possible to reduce the material consumption of the rail freight car body by 2% when using a 4 mm thick sheet of simple carbon steel. The negative point when using the proposed load-bearing floor is the volume loss, which can be up to 1 m³. However, when bulk cargo is transported, the useful volume of the rail freight car body is 70–85%.

In addition, when the proposed load-bearing floor of the SBRFC was used, the support beams were removed. As a result, it was possible to increase the carrying capacity of the rail freight car by 1.4–1.7 tons.

The proposed technical solution for future operating conditions of rail freight cars allows us to reduce the number of units in a train by 1–2 units while maintaining the gross weight of the train.

REFERENCES

- Lingaitis L., Mjamlin S., Baranovsky D., Jastremskas V. Prediction methodology of durability of locomotives diesel engines. *Eksploatacja i Niezawodność – Maintenance and Reliability*. 2012; 14(2): 154–159.
- Baranovskyi D., Muradian L., Bulakh M. The Method of Assessing Traffic Safety in Railway Transport. In: IOP Conference Series: Earth and Environmental Science. 2021; 042075: 1–6.
- Bulakh M., Okorokov A., Baranovskyi D. Risk System and Railway Safety. In: IOP Conference Series: Earth and Environmental Science. 2021; 042074: 1–7.
- Pshinko O.M., Ursulyak L.V., Zheliezov K.I., Shvets A.O. To the problem of train running safety. In: IOP Conference Series: Materials Science and Engineering. 2020; 012014: 1–10.
- Shvets A. Dynamic indicators influencing design solution for modernization of the freight rolling stock. *FME Transactions*. 2021; 49: 673–683.
- Laney K., Anderson M. *Rolling stock: Locomotives and rail cars Industry and trade summary*. Washington, 2011.
- Tsygan B.G., Tsygan A.B., Mokrousov S.D., Shcherbakov V.P. *Modern car building: Organization and production technology of car steel construction*. Kremenchug, 2012.
- Wennberg D. *A light weight car body for high-speed trains – literature study*, tech. rep. KTH, Stockholm, Sweden, 2010.
- Myamlin S.V., Kebal I.U., Kolesnykov S.R. Design review of gondola cars. *Science and Transport Progress*. 2014; 6(54): 136–145.
- Lee W.G., Kim J.-S., Sun S.-J., Lim J.-Y. The next generation material for lightweight railway car body structures: Magnesium alloys. *Journal of Rail and Rapid Transit*. 2018; 232(1): 25–42.
- Shust W.C., Iler D. Variability in natural frequencies of railroad freight car components. In: *Conference Proceedings of the Society for Experimental Mechanics Series*. 2011; 1–14.
- Vijaya Ramnath B., Elanchezian C., Manickavasagam V.M., Surya Narayanan R., Sudharshan R., Pugazhendhi G. A review on sandwich composites and their advancements. *Mater Today Proc*. 2019; 16(2): 1146–1151.
- Faidzi M.K., Abdullah S., Abdullah M.F., Azman A.H., Singh S., Hui D. Geometrical effects of different core designs on metal sandwich panel under static and fatigue condition. *Journal of the Brazilian Society of Mechanical Sciences and Engineering*. 2022; 44(111): 412–423.
- Cameron C.J., Wennhage P., Göransson P. Structural-acoustic design of a multifunctional sandwich panel in an automotive context. *J Sandw Struct Mater*. 2010; 12: 684–708.
- Norms for the calculation and design of railway carriages of the Ministry of Railways of 1520 mm gauge (non-self-propelled). Moscow GosNIIV-VNIIZhT, 1996.