

## Experimental Research on the Velocity of Two Pneumatic Drives with an Element for Concurrent Motion

Marta Żyłka<sup>1\*</sup>, Zygmunt Szczerba<sup>1</sup>, Kamil Szczerba<sup>1</sup>

<sup>1</sup> Faculty of Mechanical Engineering and Aeronautics, Department of Aerospace Engineering, Rzeszów University of Technology, Al. Powstańców Warszawy 8, 35-959 Rzeszów, Poland

\* Corresponding author's email: [mzylka@prz.edu.pl](mailto:mzylka@prz.edu.pl)

### ABSTRACT

Experimental studies of a pneumatic drive system were carried out with the applied element for the concurrent movement of two pneumatic drives. The main aim of these experiments was to obtain the results of specific measurements of displacements of two piston rods of pneumatic drives in relation to different values of loads in the whole range of the travel length. On the basis of these results, the speed of piston rods of two drives was determined. The results achieved during the experiment, showed the possibility of simultaneous insertion of two pneumatic drives with the use of an element for concurrent motion. This article is a continuation of the first article which was the study of the stroke speed of pneumatic cylinders with a synchronizing element.

**Keywords:** bench tests, double-acting pneumatic actuators, speed of insertion of pneumatic drives, rehabilitation devices for passive exercises.

### INTRODUCTION

Currently, modern rehabilitation equipment appears on the market [1, 2]. In this group we can mention such elements as apparatuses or devices for conducting passive movements and active lower and upper limbs [3, 4]. These devices are usually powered by electricity [5, 6]. An example of a device with an electric actuator can be found in an ankle rehabilitation device [7]. Only a small part of it is powered hydraulically [8]. There are also devices with pneumatic drive [9, 10]. In addition, there are also flexible pneumatic actuators in rehabilitation devices [11].

In the device for the rehabilitation of human lower limbs, it is possible to use a system that implements the simultaneous movement of two pneumatic actuators. The use of pneumatic drives is justified due to characteristics similar to those of human muscles [12].

However, during the displacement of pneumatic drive with different external load, uneven displacement of their piston-rings can be

observed. Compressed air is compressible, which means that it is difficult to achieve the same displacement of the air drive with varying loads [13, 14]. Additionally, it is also influenced by differentiated own resistance of cylinder pistons [15, 16].

The problem of non-concurrent movement of drives under different external loads can be solved, for example, by using throttle valves, proportional valves or an electropneumatic servo drive. The throttle valves [17, 18] are installed in each conduit of supply to the actuator chamber and the air flow is adjusted appropriately with a knob. It is a laborious process. Another option is to use electronically controlled proportional valves [19]. They use a system to measure the position of the piston rods of the drives. However, they are expensive and their construction is complex.

To obtain the same speed of the two drives, it is possible to use systems that are less complicated than those mentioned and are implemented by a pneumatic technique without electronic components.

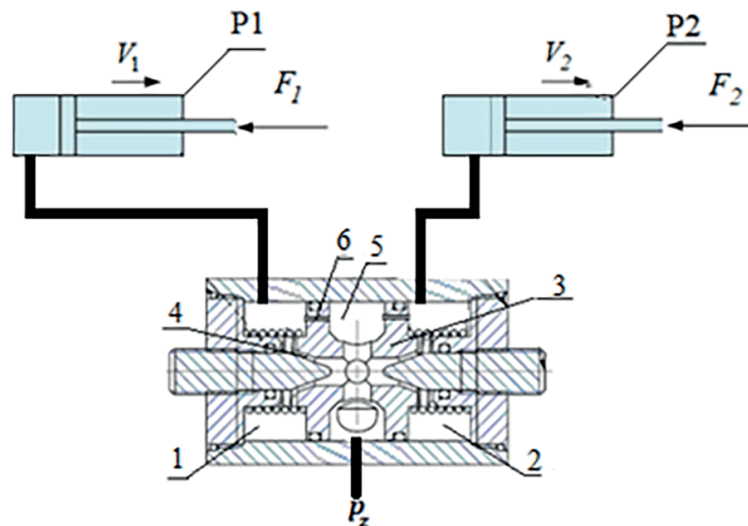

**Fig. 1.** Diagram of two pneumatic drives with an element for concurrent motion (cross-section), where: 1 – left pressure chamber; 2 – chamber pressurized right; 3 – slider; 4 – microslot; 5 – area in equalize pressure; 6 – channel in the slider; P1, P2 – actuator 1 and 2;  $F_1$ ,  $F_2$  – load forces 1st and 2nd actuator;  $p_z$  – supply pressure;  $V_1$ ,  $V_2$  – actuator speed 1 and 2

## PNEUMATIC ELEMENT IN THE REHABILITATION DEVICE

A utility model of the element was designed and made (Fig. 1) for the synchronization of displacement of two pneumatic actuators [20].

During the action of displacement of the piston rods (Fig. 1), when the P1 and P2 actuators are loaded with the same force, the spool 3 is in the middle position. When the pneumatic cylinder (P1) is loaded with a greater force  $F_1$ , the pressure in the chamber 1 is increased, and the pressure in the chamber 2 is reduced. Consequently, a pressure difference is created in pressure chamber 1 and pressure chamber 2. Consequently, the slider 3 is moved in the direction of right pressure chamber 2 with a smaller pressure.

By placing the channel in the slider 6, the pressure in the area into equalize pressure 5 is equalized.

The arrangement shown in Figure 1 can be used with exercise equipment. The synchronization of the movement of both piston rods is performed by an original synchronizing valve [20]. The need to ensure such synchronization results of clinical observations showing that the most effective rehabilitation results are obtained during simultaneous exercises of both healthy and paralyzed limbs [21, 22].

Performing the movement of two lower extremities occurs in passive and active exercises, contributes to developing and maintaining a full range of movements in the joints [23, 24, 25], and prevents the formation of muscle contractures [26, 27].

The idea of developing a rehabilitation device for passive exercises of the human lower extremities [28] is to reduce the waiting time for rehabilitation, improve the quality of life of the patient and the physiotherapist, and increase the access to rehabilitation also for the elderly. After consultation with relevant experts in the field of rehabilitation, indications have been developed and include: neurological and orthopedic-surgical patients, including: fractures in the lower limb, stroke, multiple sclerosis, cerebral palsy, prolonged immobilization, etc.

The structure of the rehabilitation device [28] is simple and can be adapted to the dimensions of the patient. The entire structure of the device is portable and enables rehabilitation on the patient's bed. Figure 2 shows a pneumatic rehabilitation device for passive exercises, designed in Autodesk Inventor 2017.

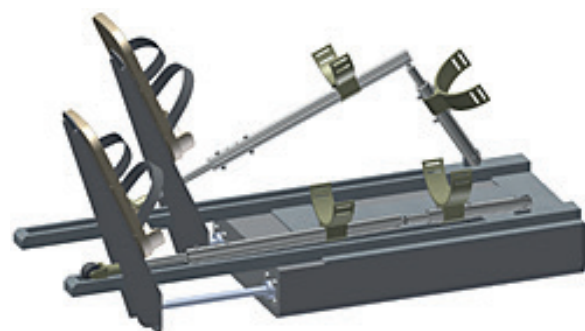

**Fig. 2.** Pneumatic rehabilitation device for passive exercises

The presented rehabilitation device (Fig. 2) is designed to: help a physiotherapist in everyday hard work, reduce rehabilitation costs, increase accessibility and shorten the waiting time for rehabilitation. A rehabilitation device was designed for the target group with a height of 1.5 m to 1.65 m [29, 30]. The device is intended for the rehabilitation of the knee joint and the hip joint bending and straightening. In the rehabilitation device (Fig. 2), you can use a system that realizes the simultaneous operation of two pneumatic actuators. The pneumatic element presented in Figure 1 can be applied to the rehabilitation device presented in Figure 2.

### THE REHABILITATION DEVICE WITH THE PNEUMATIC SYSTEM

The purpose of the research was to see and prepare graphs of the insertion of pneumatic actuators at different values of the load on these elements ( $p_1 \neq p_2$ ), which shows the situation when one limb is in a good health condition and the other is struggling with some illness.

The subjects of these researches were two pneumatic actuators, with the parameters: piston rod movement range 0.4 m with the piston diameter volume 0.04 m.

The ND1, ND2 pneumatic actuators (Fig. 3) are to replace the physiotherapist. The piston rods of PR1, PR2 drives force the movement of the K1 and K2 legs (healthy and diseased limbs). Based on the literature [29, 31], a range of values was adopted for the loading pressure of the PRL1, PRL2 pneumatic cylinders amounts to  $1.01 \cdot 10^5 \text{ Pa} - 3.97 \cdot 10^5 \text{ Pa}$ . Also, as the literature mentions [32], the pressures on the actuators selected amount to 30% of the difference in load force: ND1 the limb with a good healthy condition and ND2 the limb struggling with some illness.

Figure 3 shows the operation diagram of the rehabilitation device with the pneumatic system: extension and bend of the bottom limbs with the healthy limb K1 and the sick limb K2 marked, SO1, SO2 pneumatic actuators and PR1, PR2 piston rods PR1, PR2 pneumatic actuators ND1, ND2, forcing the movement of the bottom limbs.

Measurements of displacements were made with the use of a parametric displacement transducer. On the basis of the obtained motion measurements of the two pneumatic drives, the speed of their piston rods was determined.

Based on the literature [33, 34], the displacement time of the pneumatic drives was assumed. The passive exercises of the rehabilitated person are exercises that the therapist

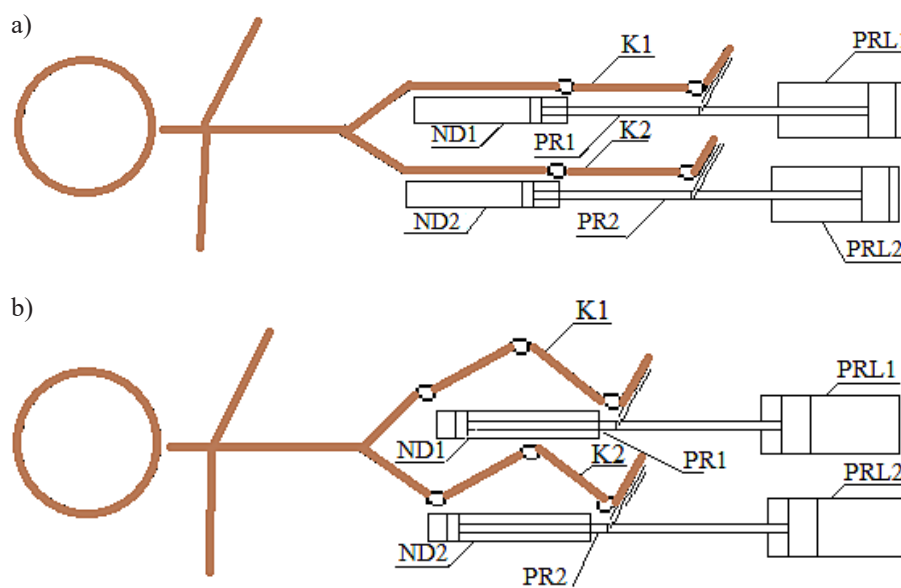

**Fig. 3.** Diagram of a system with two pneumatic drives applied to a rehabilitation equipment: a) movement limb extension, b) limb flexion movement, where: K1 – healthy limb; K2 – sick limb; PRL1 – loading cylinder in healthy limb; PRL2 – loading cylinder in affected limb; ND1 – pneumatic actuator forcing the limb movement lower K1; ND2 – pneumatic forcing actuator lower limb movement K2; PR1 – piston rod of the actuator forcing the movement of the limb K1; PR2 – piston rod of the actuator forcing the movement of the limb K2

performs without his/her participation. Movements of the limbs should move harmoniously and gently so that the patient does not cause pain. Therefore, the threshold speed was assumed to be 0.025 m/s.

## TEST METHOD

To confirm that the system of two pneumatic cylinders with an element for concurrent motion can be used in rehabilitation devices, an experiment test was carried out. The purpose of the experimental research was to obtain measurements of the displacement of the piston rods of two pneumatic drives. Based on the measurements obtained, the piston rod insertion speed of the two piston rods of pneumatic drives was determined.

## RESEARCH POSITION

It has been assumed that the maximum working pressure will not exceed  $2.4 \cdot 10^5$  Pa. At the same time, the displacement values of the PR1 and PR2 piston rods of the ND1, ND2 pneumatic drives were read. The synchronizing element was placed at the outlet of the chambers of the pneumatic actuators that were tested. The article [35] presents the speed test of extension of two pneumatic drives with the element for simultaneous movement.

The reading of the measurement results was made in the designed measurement system using the DASYLab program.

Three measurements were carried out, in which (Fig. 4) the piston rods PR1, PR2 of the tested objects ND1, ND2 - were integrated with the piston rods L1, L2 of pneumatic drives that

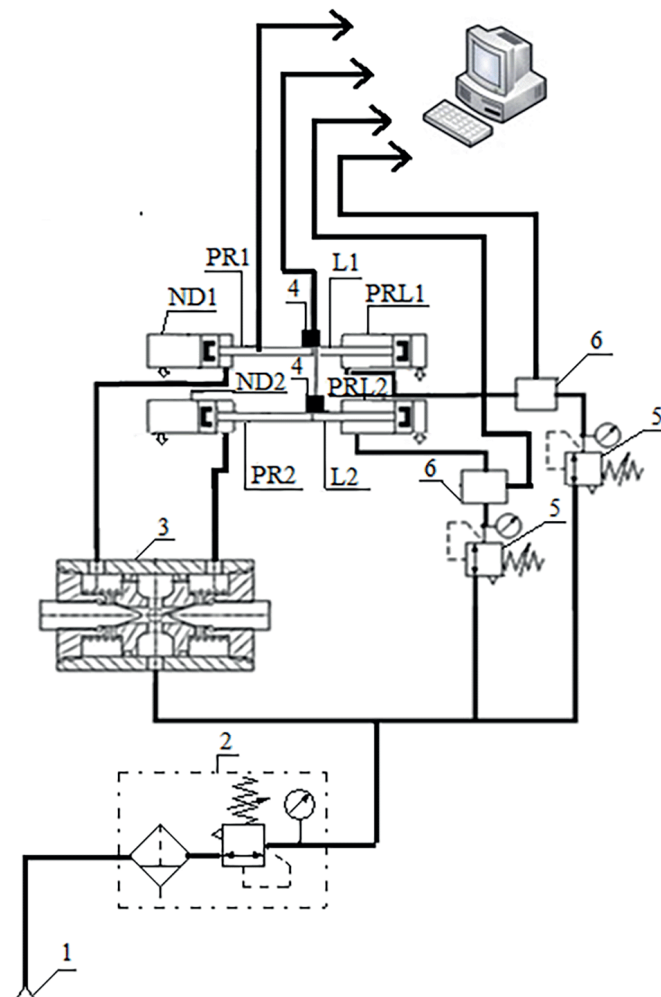

**Fig. 4.** Scheme of the research position: ND1, ND2 – tested object (double-acting pneumatic cylinders), PR1, PR2 – piston rods of the tested object, PRL1– loading cylinder in the healthy limb; PRL2 – loading cylinder in the affected limb; L1 – the piston rod of the pneumatic drive loading the healthy limb, L2 – the piston rod of the pneumatic drive loading the affected limb, 1 – supply pressure, 2 – air preparation unit, 3 – synchronizing element, 4 – actuator displacement transducers, 5 – valves reduction, 6 – pressure sensor

fulfill the load function PR1, PR2. The appropriate pressure was set with the reduction pneumatic valves. The measurements were made pneumatic drives piston rods were loaded with the following pressure: the first study – piston rod PR1 –  $p_1 = 1.01 \cdot 10^5$  Pa, piston rod PR2 –  $p_2 = 1.32 \cdot 10^5$  Pa; second study – piston rod PR1 –  $p_1 = 1.83 \cdot 10^5$  Pa, piston rod PR2 –  $p_2 = 2.38 \cdot 10^5$  Pa; third study – piston rod PR1 –  $p_1 = 2.64 \cdot 10^5$  Pa, piston rod PR2 –  $p_2 = 3.44 \cdot 10^5$  Pa.

### MEASUREMENTS RESULTS

The PR1 piston rods (Fig. 4) of the tested objects ND1 were loaded with the pressure amounted to  $p_1 = 1.01 \cdot 10^5$  Pa, piston rod PR2 of the tested objects ND2 with the pressure  $p_2 = 1.32 \cdot 10^5$  Pa. The stroke of the piston rods PR1 and PR2 of two actuators (ND1, ND2) was measured by means of actuator displacement transducers 4.

On the basis of the measurement results, the displacement of the PR1, PR2 insertion of the piston rods PR1, PR2 of the tested objects ND1, ND2 was appointed. The discrepancy in the velocity values of the insertion of the piston rods PR1, PR2 is shown in Figure 5 below.

The average velocity  $V_{1A}$  of piston rods PR1 was at the level 0.020 m/s. The average velocity  $V_{2A}$  of piston rod PR2 was 0.019 m/s. The relative velocity  $RV$  of the pneumatic drive piston rods PR1, PR2 was determined according to the relation (1).

$$RV = \frac{V_{1A} - V_{2A}}{V_{1A}} \cdot 100 [\%] \quad (1)$$

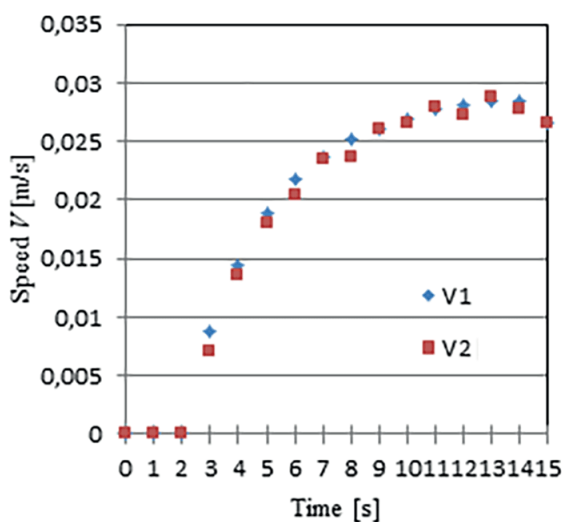

Fig. 5. The course of the velocity V1, V2 of pneumatic drives piston rods

where:  $V_{1A}$  is the average velocity of piston rods PR1 of the tested object ND1 [m/s] and  $V_{2A}$  – the average velocity of piston rod PR2 of the tested object ND2 [m/s].

Relative velocity  $RV$  of piston rods PR1 and PR2 of the tested objects ND1, ND2 unequally loaded –  $p_1 = 1.01 \cdot 10^5$  Pa and  $p_2 = 1.32 \cdot 10^5$  Pa, designated according to the relation (1) has value 2.6%.

The first analysis of the study shows (Fig. 5) that at the supply pressure  $p_z = 2.4 \cdot 10^5$  Pa, as well as the loading of the piston rods with the pressure  $p_1 = 1.01 \cdot 10^5$  Pa and  $p_2 = 1.32 \cdot 10^5$  Pa, the speed exceeds the adopted threshold value by 0.008 m/s (0.025 m/s). Due to the fact that the threshold value is only slightly exceeded, the synchronizing element can be used in rehabilitation equipment for exercises of the lower extremities.

The next study, (Fig. 4) the piston rods PR1 of the tested objects ND1 were loaded with the pressure amounted to  $p_1 = 1.83 \cdot 10^5$  Pa, piston rod PR2 of the tested objects ND2 with the pressure  $p_2 = 2.38 \cdot 10^5$  Pa. The discrepancy in the velocity values of the piston rods PR1, PR2 is shown in Figure 6.

$V_{1A}$  and  $V_{2A}$  of both piston rods PR1 and PR2 is 0.02 m/s. The relative velocity  $RS$  of the pneumatic cylinders, differently loaded ( $p_1 = 1.83 \cdot 10^5$  Pa and  $p_2 = 2.38 \cdot 10^5$  Pa), calculated according to the formula (1), has a value of 1.5%.

On the other hand, when analyzing the measurement results from Figs. 5 and 6, it was found that the speed variation of the pneumatic drives piston rods. With the load  $p_1 = 1.01 \cdot 10^5$  Pa and

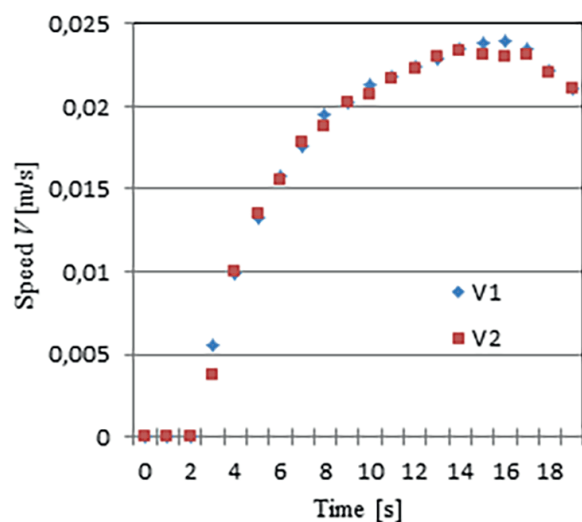

Fig. 6. The course of the velocity V1, V2 of pneumatic drives piston rods

$p_2 = 1.32 \cdot 10^5$  Pa – *RS* the average velocity of the tested object ND1 was 0.020 m/s, naughtly the average velocity of the tested object ND2 was 0.019 m/s. However, with the load  $p_1 = 1.83 \cdot 10^5$  Pa,  $p_2 = 2.38 \cdot 10^5$  Pa, the average velocity of both  $V_{1A}$ ,  $V_{2A}$  was with the value of 0.020 m/s. This is a slight difference in velocity, which is 0.001 m/s, and results from an increase in the load on the tested object ND1, ND2.

According to Figure 6, at the supply pressure  $p_z = 2.4 \cdot 10^5$  Pa and the assumed load on the pneumatic drive piston rods PR1, PR2 of the tested objects ND1, ND2, the velocity exceeds the adopted threshold value by 0.003 m/s (0.025 m/s). Due to the fact that the adopted threshold speed is only slightly exceeded, the synchronizing element can be applied in rehabilitation equipment for exercises of the bottom limbs.

In a recent study, (Fig. 4) piston rods PR1 of the tested objects ND1 was loaded with the pressure amounted to  $p_1 = 2.64 \cdot 10^5$  Pa, piston rod PR2 of the tested objects ND2 with the pressure  $p_2 = 3.44 \cdot 10^5$  Pa. The discrepancy in the velocity values of the piston rods PR1, PR2 is shown in Figure 7.

For the PR1 the average velocity ( $V_{1A}$ ) is 0.018 m/s. The value of the average velocity ( $V_{2A}$ ) the PR2 is 0.016 m/s. According to the dependence (1), the relative speed *RS* of the two tested objects ND1, ND2, with unequally loads ( $p_1 = 2.64 \cdot 10^5$  Pa and  $p_2 = 3.44 \cdot 10^5$  Pa), has a value of 11.6%. This difference is mainly related to the differentiated resistance of the cylinder pistons.

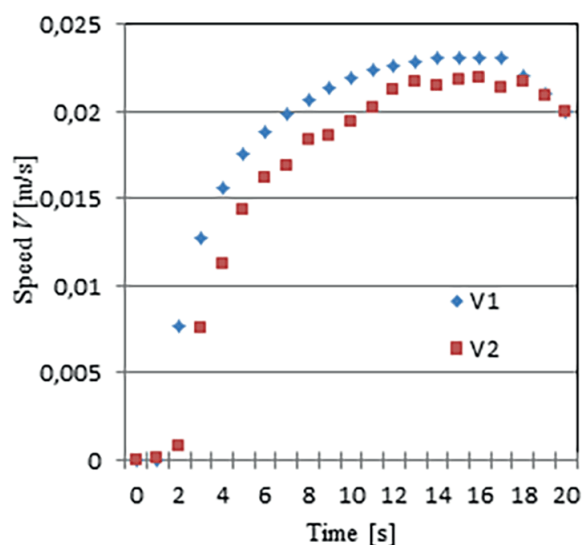

Fig. 7. The course of the velocity V1, V2 of pneumatic drives piston rods

When analysing the results of the measurements presented in Figures 6 and 7, we can notice a decrease in the velocity of the pneumatic actuators. With the load  $p_1 = 1.83 \cdot 10^5$  Pa and  $p_2 = 2.38 \cdot 10^5$  Pa – the average velocity  $V_{1A}$  was 0.020 m/s, whereas  $V_{2A}$  was 0.019 m/s. However, with the load  $p_1 = 2.64 \cdot 10^5$  Pa,  $p_2 = 3.44 \cdot 10^5$  Pa, the average velocity  $V_{1A}$  is 0.018 m/s, however  $V_{2A}$  is 0.016 m/s. For the first load, the difference  $V_{1A}$  is 0.002 m/s, while for  $V_{2A}$  it is 0.004 m/s. It is caused by an increase in the load on the tested object (pneumatic drive).

According to the data (Fig. 7), at the supply pressure  $p_z = 2.4 \cdot 10^5$  Pa and the assumed load on the piston rods, the speed at least exceeds the adopted threshold value by 0.003 m/s. Considering that the value is only slightly exceeded, the synchronizing element, with the parameters presented, can be applied to the rehabilitation equipment for passive exercises of the bottom legs.

## CONCLUSIONS

The presented element for the concurrent movement of pneumatic drives can be used for rehabilitation equipment. Effective rehabilitation results are obtained during simultaneous exercise of both limbs (healthy and dysfunctional). The concurrent movement of two drives with different external load can be realized by using different types of valves and an electro-pneumatic servo drive system. Some of them are relatively expensive and complicated solutions.

Three measurements were carried out with the following parameters: piston rod movement range 0.4 m with piston diameter volume 0.04 m.

They were performed on a measuring stand (Fig. 4), the maximum working pressure will not exceed  $2.4 \cdot 10^5$  Pa. Research on the movement (retraction) of the piston rods PR1, PR2 of the tested object was carried out. ND1, ND2 with the synchronizing element were measured at different load values, which shows the situation when one limb is sick and the other limbs are healthy.

Based on the results of measurements of displacement of actuator piston rods, the displacement values of their retraction velocity were determined.

When analysing the results of the measurements of the average speed of the piston rods, it can be seen that in the first measurement, concerning the load  $p_1 = 1.01 \cdot 10^5$  Pa of the piston

rod PR1 and the load  $p_2 = 1.32 \cdot 10^5$  Pa piston rod PR2, the velocity value  $V_{1A}$  is 0.020 m/s, but  $V_{2A}$  is 0.019 m/s. In a subsequent study, with the pressure of the piston rod PR1  $p_1 = 1.83 \cdot 10^5$  Pa and the piston rod PR2  $p_2 = 2.38 \cdot 10^5$  Pa, the velocity value  $V_{1A}$  however  $V_{2A}$  is 0.020 m/s. Last study, on the load of the piston rod PR1 with the value  $p_1 = 2.64 \cdot 10^5$  Pa and the pressure of the piston rod PR2 with the pressure  $p_2 = 3.44 \cdot 10^5$  Pa, the velocity  $V_{1A}$  is 0.018 m/s,  $V_{2A}$  is 0.016 m/s.

The measurement results obtained showed that the lower the load on the pneumatic cylinders was, the higher the velocity of the pneumatic drives.

Comparing the graphs (Figs. 5–7), one can notice a certain discrepancy between the velocity  $V_{2A}$  of the tested object of PR2 and the velocity  $V_{1A}$  of the test object of the PR1. The speed  $V_{2A}$  of the tested object of PR2 is slower than the velocity  $V_{1A}$  of the tested object of PR1.

According to the aim of the investigation, the criterion of using the synchronizing element was adopted for the analysis. It can be applied with the load parameters: first when the PR1 –  $p_1 = 1.01 \cdot 10^5$  Pa, and piston rod PR2 –  $p_2 = 1.32 \cdot 10^5$  Pa; the second when the piston rod PR1 –  $p_1 = 1.83 \cdot 10^5$  Pa, and piston rod PR2 –  $p_2 = 2.38 \cdot 10^5$  Pa; third when the piston rod PR1 –  $p_1 = 2.64 \cdot 10^5$  Pa, and piston rod PR2 –  $p_2 = 3.44 \cdot 10^5$  Pa.

Comparing the graphs (Figs. 5–7), it can be seen that the speeds of movement of the piston rods move smoothly and softly to the end of the range of motion. Such speeds of movement in passive lower limb exercises are beneficial for the patient. Too fast or sudden movement of the exercised limb can damage the structure of the knee or hip joint.

The research results confirmed the correctness and effectiveness of the innovative system of a pair of pneumatic actuators controlled by a specially designed element that synchronizes their movement in the rehabilitation device for passive exercises in the lower extremities.

The rehabilitation device presented in the article with a system of two drives and an element for their concurrent movement has some limitations. The first limitation is related to the height of the patient. A rehabilitation device was designed for the target group with a height of 1.5 to 1.65 m. Patients above or below the assumed height compartment will not be able to use the rehabilitation device presented in the article. The second limitation concerns the weight of the patients (they are people in the range of 40 to 110 kg). To select the

appropriate diameters of the drive pistons, it was necessary to calculate the force that the actuator must use to move the human lower limb.

The two pneumatic actuator control system presented in the article can be used in rehabilitation equipment for passive leg exercises. It can be the basis for the development of a number of innovative solutions used in rehabilitation engineering, such as: rehabilitation manipulators, active standing frame devices, exoskeletons, orthopedic equipment, etc.

## REFERENCES

1. Chakraborty D., Rathi A., et al. Design of a Stephenson III six-bar path-generating mechanism for index finger rehabilitation device using nature-inspired algorithms. *Neural Computing and Applications*. Springer. 2021; 1–15.
2. Khaled I., Faller L.M. Development of A Customized Rehabilitation Device Using Additive Manufacturing. *The 14th Pervasive Technologies Related to Assistive Environments Conference*. 2021.
3. Pasker C.V., Huerta C. et al. PARKIBIP Feedback Wearable Rehabilitation Device: Market Analysis and Enhancements. *2021 IEEE International Symposium on Medical Measurements and Applications*. IEEE, 2021.
4. Curio E.M., Carbone G. Mechatronic Design of a Robot for Upper Limb Rehabilitation at Home. *Journal of Bionic Engineering*. 2021; 18(4): 857–871.
5. Tang D., Xiao L. Recent Advances on Ankle Rehabilitation Device. *Recent Patents on Engineering*. 2020; 14(1): 56–68.
6. Ullas U., Rajendrakumar P.K. Design of a Low-Cost Lower Limb Rehabilitation Exoskeleton System. *IOP Conference Series: Materials Science and Engineering*. 2021; 1132(1).
7. Akagi A. et al. Development of a Rehabilitation and Training Device Considering the Ankle Degree of Freedom. *Journal of Robotics and Mechatronics*. 2020; 32(3); 673–682.
8. Bai X., Ewins D., Crocombe A.D., Xu W. A biomechanical assessment of hydraulic ankle-foot devices with and without micro-processor control during slope ambulation in trans-femoral amputees. *PloS one*. 2018; 13(10): e0205093.
9. Li B., Cao H., Greenspan B., Lobo M.A. Development and evaluation of pneumatic actuators for pediatric upper extremity rehabilitation devices. *The Journal of The Textile Institute*. 2021; 1–8.
10. Tian W., Suzuki Y., Akagi T., Dohta S., Kobayashi W., Shinohara T., Mohd A. Development of Wrist Rehabilitation Device Using Extension Type Flex-

- ible Pneumatic Actuators with Simple 3D Coordinate Measuring System. *International Journal of Automotive and Mechanical Engineering*. 2021; 18(4): 9158–9169.
11. Koter K., Szulc W. Examination of Pneumatic Bellows for the Rehabilitation of the Human Jaw. In *Biocybernetics and Biomedical Engineering—Current Trends and Challenges*, Springer, Cham; 2022: 29–37.
  12. Tondu B. Towards an efficient inverse static model of a Festo actuator made of two antagonist muscles for hybrid control of its position and stiffness. *arXiv preprint arXiv*. 2021; 2104.13167.
  13. Jamian S., Salim S.N.S., Kamarudin M.N., Zainon M., Mohamad M.S. Abdullah L., Hanafiah M.A.M. Review on controller design in pneumatic actuator drive system. *Telkomnika*. 2020; 18(1): 332–342.
  14. Inoue Y. et al. Application to Pneumatic Servo System in Bilateral Control Based on Wave Variable. *IEEE/SICE International Symposium on System Integration (SII)*. IEEE, 2020; 460–464.
  15. Jiménez M., Kurmyshev E., Castañeda C.E. Experimental study of double-acting pneumatic cylinder. *Experimental Techniques*. 2020; 44(3): 355–367.
  16. Cococi V.N., Safta C.A., Călinoiu C. Parameter tuning process for a closed-loop pneumatic actuator. In *IOP Conference Series: Earth and Environmental Science*. IOP Publishing, 2021; 664(1): 012030.
  17. Węsierski Ł.N. *Pneumatics. Elements and layouts*. Wyd. UR; 2015.
  18. Szenajch W. *Pneumatic drive and control*. Wyd. PWN; 2016.
  19. Cococi V.N., Călinoiu C., Safta C.A. 2021. Pneumatic Actuator Controlled by Proportional Valve. Experimental results. In *E3S Web of Conferences*. EDP Sciences. 2021; 286: 04010.
  20. Żyłka M., Szczerba Z. An element that synchronizes the work of two actuators. *Utility model number W.126971*, 2020.
  21. Dega W. *Orthopedics and rehabilitation*. PZWL; 2019.
  22. Laidler P. *Stroke Rehabilitation Structure and Strategy*. Wyd PZWL; 2021.
  23. Paśniczek R. *Bioengineering in rehabilitation of the musculoskeletal system*. Oficyna Wydawnicza PWN; 2021.
  24. Zembaty A. *Kinesitherapy*. Wyd. Kasper; 2003; 1.
  25. Ebel-Paprotny G., Taxhet G., Wappelhorst U. (Eds.). *Leitfaden Physiotherapie*. Elsevier Health Sciences; 2017.
  26. Rogala J., Kozak-Szkopek E. Nurses knowledge about geriatric problems. *Nursing problems*. 2021; (3): 338–345.
  27. Lewera D. *Stroke*. Wyd. Continuo. Wrocław; 2018.
  28. Żyłka M., Żyłka W., Szczerba Z. *Device for rehabilitation of lower limbs*, PL 233327, 2019.
  29. Atlas of human measures - data for ergonomic design and evaluation: [http://symulatorium.zut.edu.pl/fileadmin/PUBLIKACJE/Gedliczka\\_-\\_Atlas.pdf](http://symulatorium.zut.edu.pl/fileadmin/PUBLIKACJE/Gedliczka_-_Atlas.pdf) [access: 23.12.2021]
  30. Kułaga Z., Rózdżyńska-Świątkowska A., Grajda, A., Gurzkowska B., Wojtyło M., Góźdz M., Litwin M. Percentile grids to assess the growth and nutritional status of Polish children and adolescents from birth to 18 years of age. *Medical Standards*. 2015; 12: 119–134.
  31. Winkler T. *Computer aided design of anthropotechnical systems*. WNT; 2010.
  32. Schindler-Ivens S., Desimone D., Grubich S., Kelley C., Sanghvi N., Brown D.A. Lower Extremity Passive Range of Motion in Community Ambulating Stroke Survivors. *J. Neurol Phys Ther*. 2008; 32(1): 21–31.
  33. Centonze D., Leocani L., Feys, P. Advances in physical rehabilitation of multiple sclerosis. *Current opinion in neurology*. 2020; 33(3), 255–261.
  34. Brenner I. Effects of passive exercise training in hemiplegic stroke patients: A mini-review. *Sports Med Rehabil J*. 2018; 3(3), 1036.
  35. Żyłka M.I. The Experimental Determination of the Speed of Piston Rods of Two Pneumatic Cylinders with a Synchronizing Element. *Advances in Science and Technology. Research Journal*. 2021; 15(2): 84–89.